

# Q4401

## VARIABLE RATE VOCODER



### GENERAL DESCRIPTION

The QUALCOMM Q4401 Variable Rate Vocoder is a full-duplex speech Encoder and Decoder that produces near toll-quality speech at compressed data rates of under 9.6 kilobits per second (kbps). The Q4401 provides a single-chip solution to the speech compression requirements for digital telephone, wireless communications, voice storage, and speech synthesis systems. The Q4401 uses the proprietary QUALCOMM Codebook Excited Linear Predictive (QCELP) speech coding algorithm to achieve high speech quality at low data rates.

The Q4401 can encode speech at fixed or variable data rates. In Fixed Rate Mode, the Q4401 can code speech at rates of 4 kbps, 4.8 kbps, 8 kbps or 9.6 kbps. In Variable Rate Mode, the Q4401 automatically adjusts

the data rate from 800 bps to 8 kbps (Normal Variable Rate Mode) or from 800 bps to 9.6 kbps (Enhanced Variable Rate Mode) every 20 milliseconds (ms). When in Variable Rate Mode, the Q4401 codes speech at under 7 kbps in continuous speech applications and at under 3.5 kbps in typical two-way telephone conversations, without degrading the speech quality.

The Q4401 is a masked ROM version of a digital signal processor (DSP) device. Digitized speech is transferred to and from the Q4401 via a digital serial interface that connects to a 64 kbps  $\mu$ -law or A-law speech codec. Compressed speech packets are transferred to and from the Q4401 via an 8-bit parallel data bus interface that connects to standard microprocessor buses. The Q4401 is also controlled via this processor interface.

# CONTENTS

FUNCTIONAL OVERVIEW .....	3-4
QCELP Encoder .....	3-4
QCELP Decoder .....	3-5
Frame Timing .....	3-5
PCM Interface .....	3-5
Processor Interface .....	3-5
Input Muting .....	3-6
Output Muting .....	3-6
Output Volume Control .....	3-6
Tone Generator .....	3-6
VOX - Voice Activated Switch .....	3-6
Audio Loop Back .....	3-7
Packet Loop Back .....	3-7
OPERATING MODES .....	3-7
Q4401 Variable Rate Vocoder Initialization .....	3-7
Speech Encoding and Decoding .....	3-8
Fixed Rate Mode .....	3-9
Variable Rate Mode .....	3-9
Average Rate Limit .....	3-9
VOX Mode .....	3-10
Sleep Mode .....	3-10
Sample Slipping .....	3-10
OPERATIONAL INTERFACES .....	3-11
System Interface .....	3-11
RESET/ .....	3-11
CLKIN and CLKIN2 .....	3-11
VRS .....	3-12
CLKOUT .....	3-12
PCM Interface .....	3-12
TXD and RXD .....	3-12
TXCLK and RXCLK .....	3-12
TXSTB and RXSTB .....	3-12
TXBF and RXBE .....	3-13
Processor Interface .....	3-13
RD/ and WR/ .....	3-13
D0 to D7 .....	3-13
Frame Timing .....	3-13
Q4401 Variable Rate Vocoder and Processor Data Transfer .....	3-14
Tx and Rx Frame Data Bit Definition .....	3-15
Read and Write Protocol .....	3-15

Q4401 VARIABLE RATE VOCODER COMMANDS .....	3-19
Packet Transfer Error Conditions .....	3-20
Tx Frame Command .....	3-21
Rx Frame Command .....	3-23
Tx Frame Rate Only Command .....	3-24
Reinitialize Background Noise Estimate Command .....	3-25
Diagnostic Test Command .....	3-26
Sleep Mode Command .....	3-27
VOX Command .....	3-28
Initialize Command .....	3-30
Output Volume Control Command .....	3-31
Test Result Command .....	3-32
Tone Generation Command .....	3-33
Input Muting Command .....	3-34
Output Muting Command .....	3-35
Advance Tx Frame +1 Command .....	3-36
Slip Tx Frame -1 Command .....	3-36
Advance Rx Frame +1 Command .....	3-37
Slip Rx Frame -1 Command .....	3-37
Average Rate Limit Command .....	3-38
Audio Loop Back Command .....	3-39
Packet Loop Back Command .....	3-40
Software VRS Command .....	3-41
PCM Interface Command .....	3-42
TECHNICAL SPECIFICATIONS .....	3-43
Pin Descriptions (PQFP Package) .....	3-43
Pin Descriptions (TQFP Package) .....	3-44
Electrical Specifications .....	3-45
Absolute Maximum Ratings .....	3-45
DC Electrical Characteristics .....	3-45
Timing Characteristics .....	3-46
Q4401 VARIABLE RATE VOCODER PACKAGING .....	3-52
APPLICATIONS INFORMATION .....	3-54
REFERENCES .....	3-54

## FUNCTIONAL OVERVIEW

Figure 1 shows the functional block diagram of the Q4401. Each of the functions in this diagram is explained in detail in the following sections.

### QCELP ENCODER

The QCELP Encoder is the most complex function of the Q4401 Variable Rate Vocoder. The Encoder operates on one 20 ms frame at a time. Each frame contains 160 PCM samples. The encoding process includes measurement of the speech energy, data rate determination, dynamic adjustment of the rate thresholds, and encoding the speech into packets of compressed data. The Encoder provides a 25-byte packet of data to the processor every 20 ms. Each encoded packet contains one byte that represents the data rate and 24 bytes of encoded data that represent

the speech in each frame. The length of the packet depends on the data rate chosen, as shown in Figure 12. Any extra bits in the last byte of a packet are set to zero. The processor formats the valid data bits contained in the packet from the Q4401 for storage or transmission.

The Encoder operates in one of two compression modes: Fixed Rate or Variable Rate. The Fixed Rate Mode compresses the speech at a fixed data rate of 4000, 4800, 8000, or 9600 bits per second (bps). Variable Rate Mode compresses the speech at data rates of 800, 4000, or 8000 bps in Normal Variable Rate Mode and 800, 4800, or 9600 bps in Enhanced Variable Rate Mode. The Q4401 achieves near toll-quality speech with both Variable Rate Modes and data rates of 8000 bps or 9600 bps in Fixed Rate Mode.

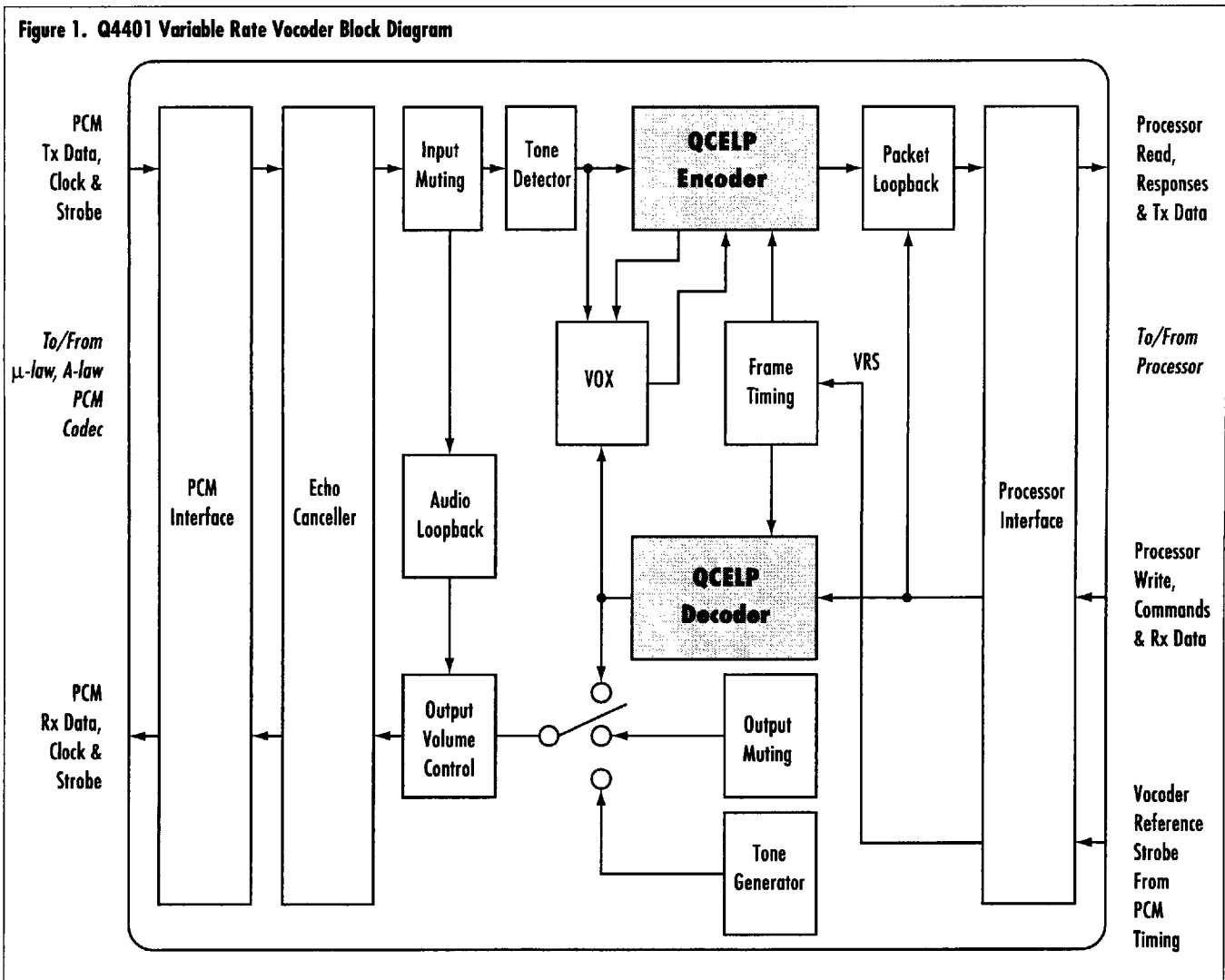

## QCELP DECODER

The QCELP Decoder receives 25-byte packets of compressed speech from the processor every 20 ms. Each decoded packet contains one byte that represents the data rate and 24 bytes of compressed data needed for reconstructing the speech. The Decoder provides a reconstructed speech output of 160 8-bit  $\mu$ -law/A-law companded speech samples every 20 ms to the PCM interface. The packets input to the Decoder contain a varying number of valid data bits depending on the data rate used to encode the frame. The processor must properly format the data from the transmission channel or storage device into the packet structure used by the Decoder.

## FRAME TIMING

The Frame Timing section of the Q4401 Variable Rate Vocoder determines the beginning of each 20 ms frame for the Encoder and Decoder. A single input signal, Vocoder Reference Strobe (VRS), provides the basis for this 20 ms timing. The Encoder frame timing and Decoder frame timing are independently set by the Tx Offset and Rx Offset from the VRS. These offsets are programmed using the Initialize command described in the *Q4401 Variable Rate Vocoder Commands* section. The frame timing is initiated by providing a single strobe (or a repetitive 20 ms signal) to the VRS input pin or by a Software VRS command to the Q4401. The initial VRS typically occurs at initialization or when the system configuration is changed.

## PCM INTERFACE

The PCM Interface of the Q4401 Variable Rate Vocoder interfaces to a  $\mu$ -law/A-law PCM codec. This interface receives and transmits 64 kbps  $\mu$ -law/A-law companded speech samples. These samples are transferred as 8-bit serial words every 125  $\mu$ s. The PCM interface is shown in Figure 2. All data is transferred synchronously with externally sourced clocks and strobes. The operation of this interface is discussed in the *Operational Interfaces* section. Two optional PCM interface handshake signals, Tx Buffer Full (TXBF) and Rx Buffer Empty (RXBE), are provided to facilitate PCM data transfer for applications that do not require the use

of a codec.

The  $\mu$ -law or A-law Codec interface format may be selected by the PCM Interface command. For more information, refer to *PCM Interface* command in the *Q4401 Variable Rate Vocoder Commands* section.

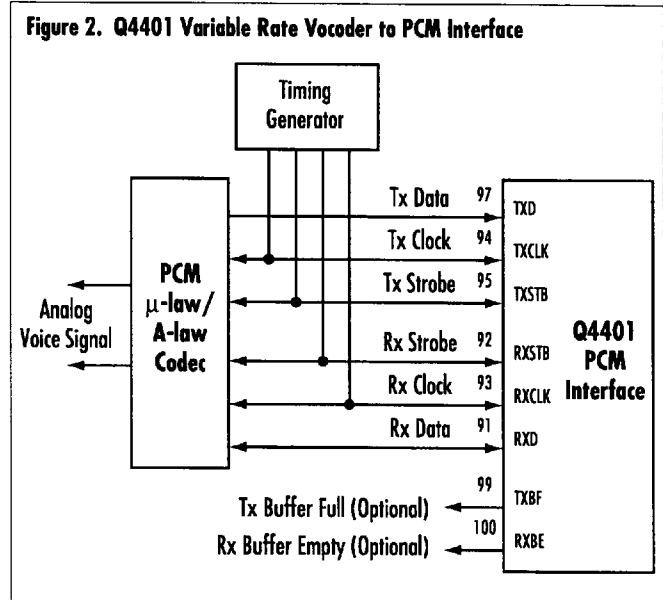

## PROCESSOR INTERFACE

The Q4401 is controlled by a processor via the 8-bit parallel processor interface. The packets of compressed data are also transmitted and received over the processor interface. Communication between the Q4401 and the processor is governed by a protocol that defines the Q4401 Variable Rate Vocoder commands and responses (described in the *Q4401 Variable Rate Vocoder Commands* section). The Q4401 acts as a slave peripheral to the processor. Therefore, the processor always initiates communication.

Commands sent to the Q4401 from the processor are called command packets. Responses sent from the Q4401 to the processor are called response packets. Data is transferred via the 8-bit data bus using the read and write signals from the processor. The processor interface is shown in Figure 3.

The Q4401 has a Sleep Mode that can be enabled when it is not in use. The power dissipation while in Sleep Mode is less than 50 mW, about 10% the power of normal operation. The Q4401 is reinitialized from Sleep Mode by an Initialize Vocoder command from the processor.

**Figure 3. Vocoder to Processor Interface**

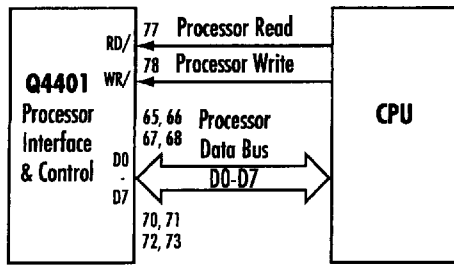

The Q4401 features two self-diagnostic tests: a RAM Test and an ALU Test. The RAM Test verifies that the RAM locations can be written to and read from properly. The ALU Test verifies that the DSP core is functioning properly.

### INPUT MUTING

The Input Muting function suppresses the input speech so that it is not encoded. Comfort noise is the only data that is encoded. The reconstructed signal at the Decoder contains only comfort noise. In Variable Rate Mode, the Encoder encodes the input speech at the low, 800 bps data rate. For more information, refer to *Input Muting* command in the *Q4401 Variable Rate Vocoder Commands* section.

### OUTPUT MUTING

The Output Muting function replaces the reconstructed speech samples with comfort noise before the samples are sent to the PCM Interface. Output muting is often used to eliminate pops and glitches that may be caused by the switching of processing paths or data sources. When the processor is aware of any system configuration changes that might cause errors to be heard, the Output Muting feature should be enabled and then disabled after the event has passed. For more information, refer to *Output Muting* command in the *Q4401 Variable Rate Vocoder Commands* section.

### OUTPUT VOLUME CONTROL

The Output Volume Control function controls the volume of the reconstructed speech samples out of the Decoder. The 16-bit value is completely programmable from the processor. The output volume control can be

varied between 42 dB of gain, 42 dB of attenuation, and muting (i.e., no output). Caution should be used when applying gain. Large gain increases can cause clipping of the speech samples sent to the codec, resulting in distortion. Also, some unavoidable quantization noise will be added when gain is applied. For more information, refer to *Output Volume Control* command in the *Q4401 Variable Rate Vocoder Commands* section.

### tone generator

The Tone Generator synthesizes single or dual frequency tones at the RXD output of the Q4401. Two completely programmable tones can be generated with arbitrary volume and duration of the tones. Tone generation overrides the voice output to the PCM interface. However, the Q4401 continues to operate during tone generation. Therefore, received packets must continue to be passed to the Q4401 Decoder to ensure that the speech is reconstructed properly when the tones are discontinued. Standard DTMF signals can be generated using this tone generator. For more information, see the *Tone Generation* command in the *Q4401 Variable Rate Vocoder Commands* section.

### VOX - VOICE ACTIVATED SWITCH

The VOX function is used in real-time, full-duplex applications where hands-free telephone operation is required. In hands-free operation, the microphone is typically near the speaker output, which can result in feedback between the speaker output and the microphone. This phenomenon, coupled with the inherent processing delay of the Q4401, will result in an echo heard by users at the far end as they speak. ("Far end" refers to the other end of the link; "near end" refers to the end with VOX Mode enabled.) VOX Mode will allow only one side of the full-duplex link to be transmitted when there is voice activity, thus removing the return path for possible echo. VOX Mode operational parameters are completely programmable and are described in the *Operating Modes* section. Also, see the *VOX* command in the *Q4401 Variable Rate Vocoder Commands* section.

## AUDIO LOOP BACK

The Audio Loop Back function causes the digitized speech samples provided to the Q4401 PCM input to be looped back to the PCM output without being processed by the Encoder. This is useful for verifying the correct operation of the PCM interface. The output PCM samples will not match the input PCM samples on a bit-by-bit basis due to the DC block implemented by the Q4401, but the speech output will still sound identical to the input. For more information, see the *Audio Loop Back* command in the *Q4401 Variable Rate Vocoder Commands* section.

## PACKET LOOP BACK

The Packet Loop Back function loops back unchanged Rx packets to the processor as Tx packets. This is useful for verifying the correct operation of the processor interface. For more information, refer to *Packet Loop Back* command in the *Q4401 Variable Rate Vocoder Commands* section.

## OPERATING MODES

The Q4401 Variable Rate Vocoder operates in a variety of modes to provide maximum performance in a wide range of applications. The two main operating modes are Fixed Rate and Variable Rate Modes. Fixed Rate Mode provides one of four selectable data rates at 4000, 4800, 8000, and 9600 bps. There are two Variable Rate Modes, Normal and Enhanced, which dynamically adjust the speech data rate for each frame based on the speech signal energy. Normal Variable Rate Mode varies the data rate between 800, 4000, and 8000 bps. Enhanced Variable Rate Mode varies the data rate between 800, 4800, and 9600 bps.

In addition to these two main operating modes, the Q4401 provides other operating modes to enhance speech compression operation. The Initialization Mode is used to configure the Q4401 Timing and Operating Mode for speech encoding and decoding. The Average Rate Limit Mode is used with Variable Rate Mode to limit the maximum average data rate to between 4000 and 9600 bps. The VOX Mode is used for hands-free operation similar to a speaker phone. Sleep Mode saves power when the Q4401 is not in use at a given time.

Sample Slipping is a mechanism that adjusts for timing differences between the PCM Interface and the transmission channel. Each of these modes is described in the following sections.

## Q4401 VARIABLE RATE VOCODER INITIALIZATION

The Q4401 Variable Rate Vocoder must be initialized at power-up, after a reset condition, or when new system parameters are required, such as when a new two-way voice connection is made. The initialization process specifies the Tx and Rx timing parameters, starts the 20 ms frame timing, and establishes the background noise estimate for the current environment.

Initialization typically starts after the assertion of the hardware RESET signal. The Initialize command may be issued by the processor 1 ms after the reset is complete to configure the Tx Offset and Rx Offset timing parameters. Tx Offset and Rx Offset determine the timing relationships between the VRS and the Tx Tick and Rx Tick, respectively. This configures the Q4401 timing so that the Tx Frame and Rx Frame commands are aligned with the internal processing of the Q4401. The Initialize command also causes the Q4401 to look for the VRS, which starts the internal frame timing. The external hardware VRS signal may be asserted any time after the Initialize command has been issued. Alternatively, the Software VRS command may be issued from the processor 250 micro seconds ( $\mu$ s) after the Initialize command has been issued. Once the VRS occurs, the Reinitialize Background Noise Estimate command should be issued to initialize the data rate thresholds. After the initialization process is complete, the Q4401 will be ready to perform speech compression via the Tx Frame and Rx Frame commands. The following is a summary of the initialization procedure:

1. Reset the Q4401 Variable Rate Vocoder (Hardware Reset or Software Reset via the Software Reset command) and wait 1 ms.
2. Issue the Configuration command.
3. Select Tx Offset and Rx Offset via the Initialize command.
4. Issue an External Hardware VRS or the Software VRS command 250  $\mu$ s after the Initialize command.

5. Initialize background noise by issuing the Initialize Background Noise Estimate command.
6. Start data transfer using the Tx Frame and Rx Frame commands.

After initialization, the first encoded frame will be a "Blanked" frame (i.e. no valid data will be present). Each frame following the "Blanked" frame will be encoded and decoded based on the parameters defined by the Tx Frame and Rx Frame commands.

## SPEECH ENCODING AND DECODING

After the initialization sequence is complete, speech encoding and decoding may begin. PCM data samples at the TXD Input are internally grouped together into 20 ms frames (160 PCM samples per 20 ms frame). These frames are encoded into packets and output to the processor every 20 ms via the Tx Frame command. The Decoder path of the Q4401 receives packets of compressed speech data from the processor every 20 ms via the Rx Frame command. Each frame of compressed speech information is decoded and provided to the RXD Output as PCM samples.

For the encoding operation, the processor receives an encoded packet of compressed speech data every 20 ms by issuing a Tx Frame command to the Q4401. The Tx Frame command must be issued within a 19 ms window after the Tx Frame Tick. (This is discussed in detail in the *Processor Interfaces* section.) Each packet of compressed speech data is transferred to the processor in the Tx Frame response packet. Due to double buffering of the packets in the Q4401, the data contained in the Tx Frame response packet corresponds to the speech encoded during the previous 20 ms frame. The Tx Frame response packet contains the data rate for the frame as well as the valid data bits. The Tx Frame command contains the maximum and minimum data rate limits for the next 20 ms frame to be processed. Alternatively, the processor can also provide data rate parameters only for the current frame being processed using the Tx Frame Rate Only command, which is discussed in the *Operational Interfaces* section. Each packet of compressed speech data received by the processor is then formatted for transmission over a digital communications channel or

for sending to a storage medium. The processing delay between the arrival of the first PCM sample in a 20 ms frame and the completion of the encoding process for that frame is approximately 47.5 ms.

The decoding process begins when the processor receives a packet of information from the transmission channel or storage medium and constructs an Rx Frame command packet to send to the Q4401. The Rx Frame command provides a frame of compressed speech data from the processor to the Q4401 for decoding. The Rx Frame command is issued every 20 ms within a 19 ms window before the Rx Frame Tick. The Rx Frame command packet contains the data rate for the frame as well as the valid data bits needed to reconstruct the speech signal. The Decoder reconstructs the speech from the received packet and provides the reconstructed PCM speech samples to the RXD output. The processing delay between the arrival of the Rx Frame command packet and transmission of the first PCM sample to the codec is approximately 3 ms.

The Q4401 contains a feature that allows selected data frames to be "Blanked" or "Erased" to reduce the effects of system noise and transmission errors. The result of system noise and transmission errors are pops and clicks heard at the Decoder end. The "Blank" feature is used by the Encoder to eliminate the pops and clicks when a known disruption in the system occurs. Such disruptions could include configuration changes or transmission of a frame of control information instead of compressed speech data. The "Blank" indication is provided in the Tx Frame command and sent to the Decoder in an Rx Frame command. The "Erase" feature eliminates the pops and clicks caused by transmission errors over the transmission medium. This feature is used by the processor on the Decoder side when a packet of information is received from the transmission channel with bit errors. One bit error could have a major effect (or minor effect depending on which bits are in error) on the decoded speech quality. Therefore, when a packet is received with errors, it is best to use the "Erase" feature. The "Erase" indication is sent by the processor to the Decoder in the Rx Frame command. Both the "Blank" and "Erase" features command the Decoder to estimate what the

reconstructed frame of speech data should be without compressed speech data.

### FIXED RATE MODE

In Fixed Rate Mode, the same data rate is used for compressing and decompressing each frame. This is accomplished by setting the maximum and minimum data rate limits in the Tx Frame command to be equal. Valid fixed rates are 4000, 4800, 8000, and 9600 bps. The Decoder operates the same way as described above in the *Speech Encoding and Decoding* section.

### VARIABLE RATE MODE

Variable Rate Mode dynamically varies the data rate of each frame based on the speech signal energy. There are two Variable Rate Modes: Normal Variable Rate Mode which selects from data rates of 800, 4000, and 8000 bps, and Enhanced Variable Rate Mode which selects from data rates of 800, 4800, and 9600 bps. The Enhanced Mode will provide slightly better voice quality because of the higher data rates.

Variable Rate Mode determines the data rate for each frame based on the energy of the speech. If the signal energy is high, the maximum (or full) rate will be used. If the signal energy is at a medium level, the intermediate (or half) rate will be used. If the signal energy is low, the 800 bps data rate will be used. Full Rate is defined as 8000 bps for Normal Variable Rate Mode and 9600 bps for Enhanced Variable Rate Mode. Half Rate is defined as 4000 bps for Normal Variable Rate Mode and 4800 bps for Enhanced Variable Rate Mode.

The Tx Frame command provides the maximum and minimum data rate parameters. In Normal Mode the maximum is set to 8000 bps, and the minimum is set

to 800 bps. In Enhanced Mode, the maximum is set to 9600 bps, and the minimum remains set to 800 bps. The Tx Frame response packet contains the data rate that the Encoder selects for each frame and the compressed speech data.

The Q4401 Encoder also contains a unique feature for tracking the background noise level to optimize the voice quality and compression rate when in Variable Rate Mode. The Background Noise Estimate gradually adjusts the adaptive rate thresholds to float above the level of the background noise. A Reinitialize Background Noise Estimate command may be issued at any time to immediately set the compression rate thresholds. The processor typically issues the Reinitialize Background Noise Estimate command when the Q4401 is initialized or at the initial onset of valid PCM data to the vocoder.

The Decoder operates the same way as described in the *Speech Encoding and Decoding* section.

### AVERAGE RATE LIMIT

The Average Rate Limit command is used when the desired maximum average encoded data rate must be limited between Half Rate and Full rate for active speech. One of the Variable Rate Modes must be selected for the Average Rate Limit command to operate properly. This command will force some frames that would normally be encoded at Full Rate to be encoded at Half Rate instead. For example, an Average Rate Limit selection of  $\frac{7}{8}$  will cause 75% of the Full Rate frames to be encoded at Full Rate and 25% of the Full Rate frames to be encoded at Half Rate. The resulting maximum average is 7000 bps in Normal Mode and 8400 bps in Enhanced Mode. See Figure 4 for an example. This feature affects only the Encoder side

Figure 4. Average Rate Limit Operation During Speech

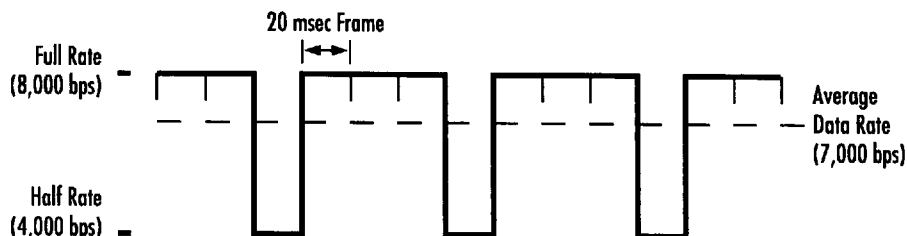

of the Q4401. The processor handles the compressed data from the Tx Frame and Rx Frame commands exactly as described in the *Speech Encoding and Decoding* section.

## VOX MODE

VOX Mode is used to eliminate potential echo during hands-free telephone operation (i.e. speakerphone applications). This mode can be used in conjunction with Fixed, Variable, or Average Rate Limit Modes. In VOX Mode, the Q4401 operates in one of three states: Idle, Tx, and Rx. The Idle state allows transmission in both directions, whereas the Tx and Rx states allow half-duplex operation only. The VOX Mode will remain in the Idle state until the Decoder signal energy and background noise energy differ by a programmable amount. Once the VOX leaves the Idle state, the active states (Tx or Rx) are entered by comparing the Encoder's signal and background noise energy to the Decoder's signal and background noise energy. The Decoder typically has priority over the Encoder. Therefore, if both users are speaking at the same time, the user at the far end will have priority.

The VOX Mode command enables and establishes the parameters for VOX Mode operation. There are five programmable parameters that enable the processor to tailor the VOX Mode operation to the specific requirements of the system. These parameters include:

- **Energy Decay Factor:** Selects the sensitivity for the near-end speech input so that it will not be cut off during pauses.
- **Background Noise Decay Factor:** Selects the rate at which the background noise estimates are allowed to increase.
- **Decoder Background Noise Floor:** Sets the lower limit of the Decoder background noise threshold. This is required because VOX Mode will not operate efficiently if the background noise is too low.
- **Decoder VOX Threshold:** Sets the receive signal (from the far end) energy threshold. VOX is not required if the receive energy from the far-end is less than 6 dB above the Decoder's background noise.

- **Encoder Weighting Factor:** Sets a weighting factor, which scales the Encoder's speech energy before the Encoder/Decoder energy comparison is made to determine which side will have priority.

For more information, see the *VOX Command* in the *Q4401 Vocoder Commands* section.

## SLEEP MODE

Sleep Mode conserves power when the Q4401 Variable Rate Vocoder is not in operation. The Q4401 can be commanded to enter the Sleep Mode by issuing the Sleep Mode command or by issuing the Diagnostic Test command. (The Q4401 will automatically enter Sleep Mode when the diagnostic tests are complete.) The power dissipation during Sleep Mode is less than 50 mW compared to almost 500 mW during normal operating conditions.

Sleep Mode essentially performs a software reset and remains in the reset condition until the processor writes an Initialize command. At that time, the initialization sequence must be performed to configure the Q4401 for desired operation.

## SAMPLE SLIPPING

Sample Slipping is a mechanism to adjust the Tx Offset and Rx Offset relative to the VRS without having to reinitialize the Q4401. This mode is available to compensate for differences between the PCM timing and the transmission channel timing.

Two alternate commands, Tx Offset + 1 and Tx Offset - 1, may be used in place of the Tx Frame command to adjust the Tx Offset either backward or forward by one PCM sample relative to the VRS. When the value of the Tx Offset is increased by one, a sample from the PCM input is deleted, and the internal Q4401 Encoder timing is shifted back one sample. When the value of Tx Offset is decreased by one, a sample from the PCM input is repeated, and the internal Q4401 Encoder timing is shifted forward one sample.

Similarly, there are two alternate commands, Rx Offset + 1 and Rx Offset - 1, that may be used in place of the Rx Frame command to adjust the Rx Offset either backward or forward by one PCM sample period relative to the VRS. When the value of Rx Offset is

increased by one, a PCM output sample is repeated and the internal Q4401 Decoder timing is shifted forward one sample. When the value of Rx Offset is decreased by one, a PCM output sample is deleted, and the internal Q4401 Decoder timing is shifted back one sample.

The Tx Offset and Rx Offset commands take effect immediately. Therefore, the timing of the Tx Frame and Rx Frame commands that follow these alternate commands must be moved accordingly, either forward or backward.

## OPERATIONAL INTERFACES

The Q4401 Variable Rate Vocoder operational interfaces are comprised of the system interface, PCM interface, and processor interface. Figure 5 shows the Q4401's interfaces. The system interface provides connections for the general purpose signals used by the Q4401. The PCM interface provides all connections necessary for interfacing to a standard  $\mu$ -law/A-law codec. The processor interface provides all connections for interfacing to a standard 8-bit microprocessor data bus. The operation and use of each of these interfaces are discussed in detail below.

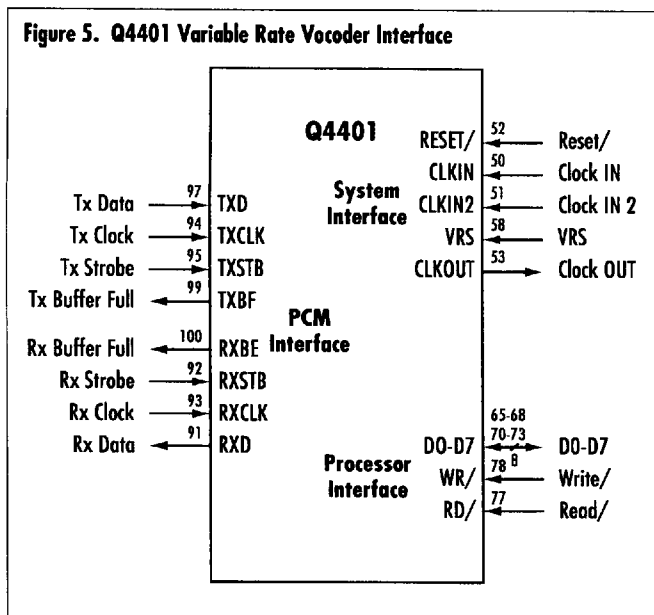

## SYSTEM INTERFACE

The system interface contains the RESET/, CLKIN, CLKIN2, VRS, and CLKOUT signals. The following is a description of each of these signals.

### RESET/

The RESET/ signal is an active "Low" input that resets the entire Q4401 Variable Rate Vocoder. A "High"-to-"Low" transition causes the Q4401 to enter the reset state and remain in this condition until the signal returns "High" again. The RESET/ signal must remain active for at least six input clock periods (198 ns). All output signals are tri-stated during reset, and all internal timers and registers are cleared. After the reset condition is removed, the Q4401 will initialize the internal QCELP algorithm and wait for the Initialize command. There must be at least 1 ms between the end of the reset condition and when the Initialize command is passed to the Q4401.

### CLKIN AND CLKIN2

The CLKIN and CLKIN2 inputs are used for the external 30 MHz clock. Two types of clocks may be used, a CMOS level clock input or a crystal clock input. If a CMOS level clock signal is used, this clock signal should be connected to CLKIN. In this case, CLKIN2 should be left open. If a 30 MHz crystal is used, then one of the two pins of the crystal should be connected to CLKIN, and the other pin should be connected to CLKIN2. In this configuration a 10 pF capacitor is required between each of these inputs and VSS (ground). Figure 6 shows a typical clock input configuration using a CMOS logic level clock input and a crystal clock input.

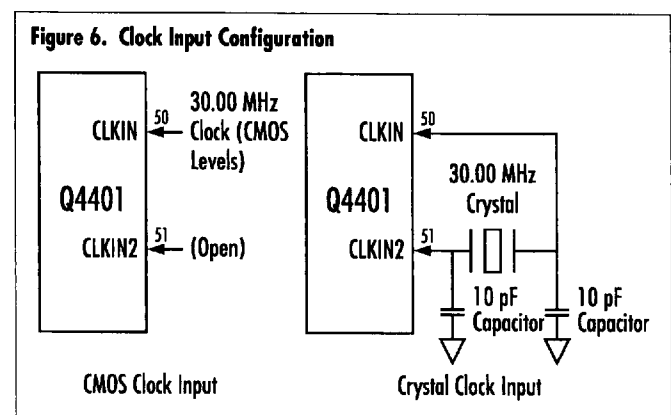

## VRS

The VRS is used to set the 20 ms frame timing for the Encoder and Decoder. This signal is used by the Q4401 to synchronize the transmission and reception of coded speech data to and from the processor. The Encoder Frame Timing and Decoder Frame Timing are independent from each other but both are derived from the VRS via the Tx-Offset and Rx-Offset parameters in the Initialize command. This input can be a single active "High" pulse occurring one time after the Initialize command has been issued or a continuous stream of pulses spaced 20 ms apart. The pulse must be "High" for at least 2  $\mu$ s, but no more than 250  $\mu$ s. The VRS signal must be asserted each time that the Q4401 has been reset or has been reconfigured by the Initialize command. The VRS function can also be performed by issuing the Software VRS command after the Initialize command has been issued.

## CLKOUT

The CLKOUT signal is a buffered version of the CLKIN signal (i.e., 30 MHz). This output can be used to clock other devices in the system.

## PCM INTERFACE

Figure 5 shows the Q4401 Variable Rate Vocoder interface to a PCM codec via the serial PCM interface. The input samples from the codec to the PCM interface control the timing of the Q4401. A frame is encoded every 160 PCM input samples or 20 ms. The TXD and RXD signals are the data lines in and out of the Q4401. The TXSTB and RXSTB signals are used to gate the data in and out of the vocoder. The TXCLK and RXCLK signals are used to clock the data in and out of the

Q4401. The TXBF and RXBE are optional signals for transferring data to and from the Q4401 without a PCM codec device.

## TXD AND RXD

TXD and RXD are the serial data input and serial data output signals. The Q4401 sends and receives serial PCM data to and from the PCM codec. The serial data word length is 8 bits, with the MSB transmitted first and the LSB transmitted last.

## TXCLK AND RXCLK

The rising edge of the TXCLK input is used to clock each of the eight TXD serial data bits from the PCM codec into the Q4401. This clocking operation is enabled by the TXSTB input. Likewise, the rising edge of the RXCLK input is used to clock each of the 8 RXD serial data bits out of the vocoder. This clocking operation is enabled by the RXSTB input. In applications where the input and output timing are synchronous, the TXCLK and RXCLK signals can be connected, and the TXSTB and RXSTB signals can be connected. The frequency of the TXCLK and RXCLK can be from 64 kHz to 15 MHz. The Tx Timing and Rx Timing between the Q4401 and the codec are shown in Figure 7.

## TXSTB AND RXSTB

The TXSTB and RXSTB inputs are used to enable the clocking of PCM samples into or out of the Q4401. These active "Low" inputs must be supplied at an 8 kHz (125  $\mu$ s) rate. The TXSTB and RXSTB inputs can pulse "Low" for one bit period or pulse "Low" for up to the entire 8-bit transfer. For more information, refer to

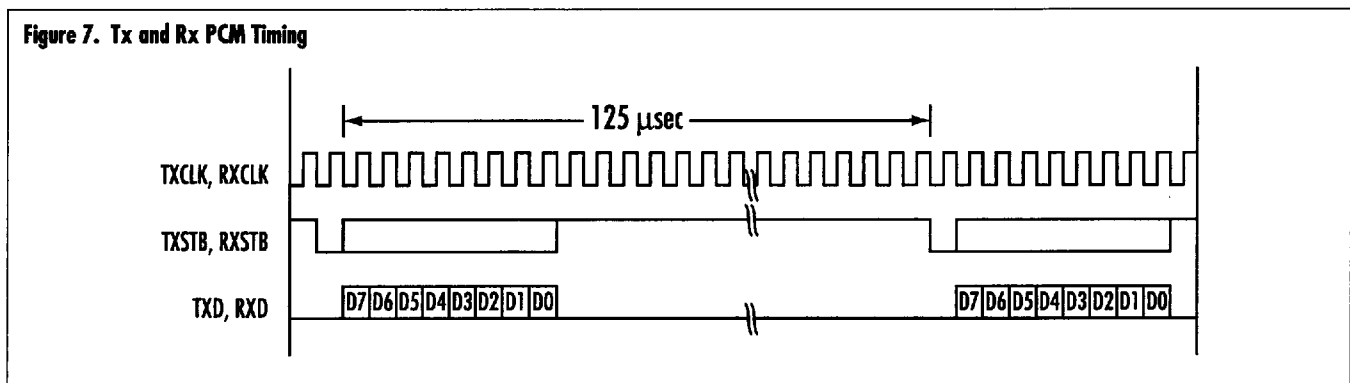

PCM Tx Timing and PCM Rx Timing under the *Timing Characteristics* section.

### TXBF AND RXBE

The optional TXBF and RXBE output signals are used when transferring PCM data to and from the Q4401 without a PCM codec. The TXBF output indicates whether or not the vocoder's PCM input buffer is full. Data input to the PCM input buffer when it is full will be lost. The RXBE output indicates whether or not the Q4401 PCM output buffer is empty. There are several applications where these signals can be used. One such application might be in a system where digitized PCM speech samples are stored in memory and a processor is used to transfer the samples to the Q4401 PCM Interface. These two handshake signals may be monitored by the processor to speed up the data transfer and minimize external circuitry. The strobes and clocks are still required by the Q4401 for proper data transfer but can be generated by the processor.

### PROCESSOR INTERFACE

The Q4401 communicates with the processor via the 8-bit parallel processor interface shown in Figure 5. All communication to and from the Q4401 must be initiated by the processor, since the Q4401 acts as a slave to the processor. Consequently, the packets sent by the processor to the Q4401 are called command packets. Packets sent by the Q4401 to the processor are called response packets. This section also contains a description of the Frame Timing, the data transfer between the Q4401 and the processor, the Tx and Rx Frame data bit definition, and the Read and Write protocol.

### RD/ AND WR/

The Read and Write inputs are active "Low" signals driven by the processor. When the RD/ signal goes "Low", the Q4401 will place one byte (8 bits) of the response register contents on the processor data bus. The rising edge of the WR/ signal is used to latch data from the processor into the Q4401.

### DO TO D7

The processor data bus is an 8-bit wide parallel bi-directional bus. Command and response information is transferred between the Q4401 and processor using this bus.

### FRAME TIMING

Transmission and reception of packets of compressed speech to and from the processor occur independently. The Tx Offset and Rx Offset parameters are used by the Q4401 to configure its internal timing with the timing of the Tx Frame and Rx Frame commands from the processor. Upon reset of the vocoder, the processor provides the Tx Offset and Rx Offset parameters (in units of PCM samples) from the VRS via the Initialize command as shown in Figure 8.

There are typically only two commands transferred between the processor and the Q4401 during each 20 ms frame. Due to double buffering of the Tx and Rx Frame data, the processor may send the Rx Frame data, via the Rx Frame command, to the Q4401 any time within a 19 ms window before the Rx Frame Tick. Similarly, the processor may obtain Tx Frame data via the Tx Frame command from the Q4401 any time within a 19 ms window after the Tx Frame Tick as shown in Figure 9.

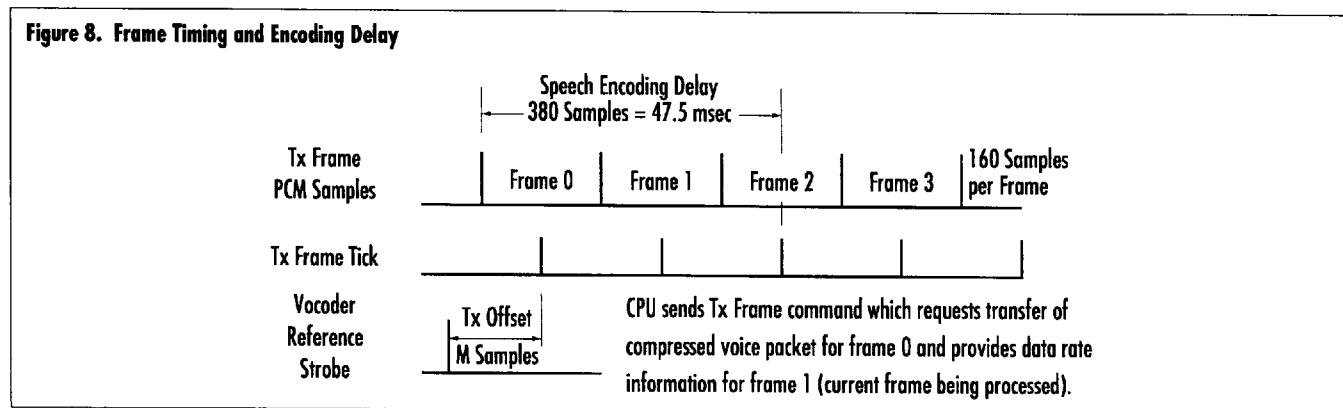

**Figure 9. Tx and Rx Frame Timing**

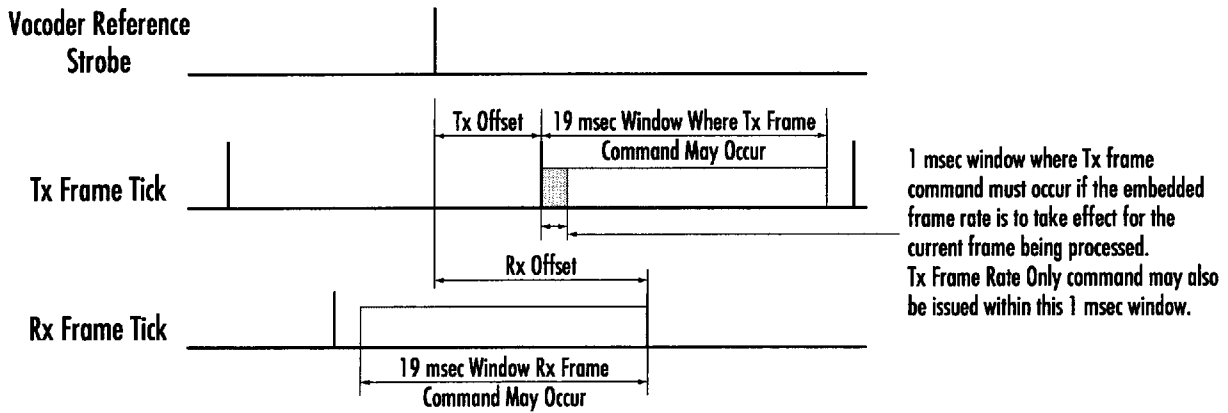

1 msec window where Tx frame command must occur if the embedded frame rate is to take effect for the current frame being processed. Tx Frame Rate Only command may also be issued within this 1 msec window.

The Tx Frame command also contains the data rate parameters for the next frame. If the data rate must change for the current frame being processed, then the Tx Frame command must be issued within the first 1 ms after the Tx Frame Tick. If the 1 ms window is missed, then the new data rate limits will not take effect until the next frame. If the data rate for the current frame must change and the Tx Frame command cannot be issued within the 1 ms window, then the Tx Frame Rate Only command may be issued. This command is simple to issue within the 1 ms window since data is not transferred and the additional processing during this period is minimal.

**Q4401 VARIABLE RATE VOCODER AND PROCESSOR DATA TRANSFER**

Data transfer between the Q4401 Variable Rate Vocoder and the processor is always initiated by sending a command packet from the processor to the Q4401. The processor will always read a response packet from the Q4401 after a command packet has been sent. The command packet always consists of a length byte, followed by a command byte, the associated data bytes (if any), and a checksum byte. Figure 10 shows the format of the command packet. The checksum byte is calculated as the binary sum of bytes 0 through n-1 with the carry bits added back in. For example, if the sum of bytes 0 through n-1 equaled 5BA (hex), then 5 would be added to BA (hex) to equal a checksum of BF (hex). If an overflow occurs when the carry bits are added back into the checksum, then the

**Figure 10. Command Packet Format**

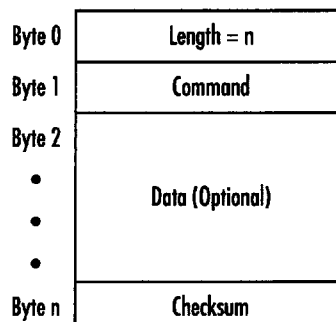

new overflow value must also be added into the checksum. The command packets from the processor are always acknowledged by the Q4401 using response packets. Response packets always contain two bytes that verify the command was received correctly. First, the Q4401 indicates whether the packet was received with a good checksum in the form of an Acknowledge (ACK - 0A hex) or Not Acknowledged (NACK - 05 hex). Second, the Q4401 indicates that it understands and is carrying out the command function by echoing the command back to the processor. Following the command echo are the associated data bytes (if any) and then a checksum byte. The checksum byte is computed in the same manner as the checksum byte in the command packet. Figure 11 shows the format of the response packet.

The processor initiates communication by only writing the length byte of a command packet to the Q4401. The processor then polls (continuously reads) the Q4401 until it signals that it is ready to receive the

**Figure 11. Response Packet Format**

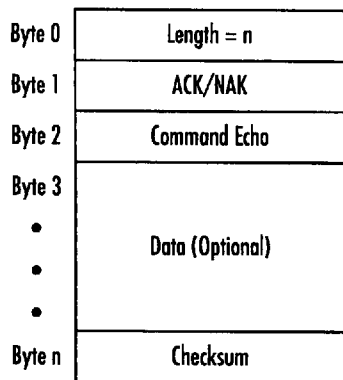

remaining bytes of the command packet. Writing the length byte orders the Q4401 to prepare to receive a command packet that is n-bytes long.

The Q4401 needs up to 27  $\mu$ s to get ready to receive the rest of the command packet. During this waiting period, the Q4401 provides a "Not Ready" (00 hex) indication when the processor reads the Q4401. After the length byte is written, the processor must continue to poll the Q4401 until the status byte changes from "Not Ready" (00 hex) to "Write Ready" (FF hex). This is an indication to the processor that all the remaining bytes of the command packet can now be written to the Q4401.

After the remaining command packet bytes have been written, the Q4401 needs up to 27  $\mu$ s to process this data and compose a response packet. During this waiting period, the Q4401 provides a "Not Ready" (00 hex) indication when the processor reads the Q4401. After the command packet is written, the processor must continue to poll the Q4401 until the status byte changes from "Not Ready" (00 hex) to "Read Ready" (55 hex). This is an indication to the processor that the response packet bytes can be read from the Q4401.

After all the bytes of the response packet have been read, the Q4401 provides a "Not Ready" indication until the length byte of the next command packet is written. The "Not Ready" indication is available for the processor to read upon power-up and after each packet transfer. Table 1 defines the status bytes that the Q4401 provides to the processor. The latency of this protocol is described in the *Read and Write Protocol* section.

**Table 1. Status Bytes to the Processor**

STATUS	MEANING
00 Hex	Not Ready
55 Hex	Read Ready
FF Hex	Write Ready

**TX AND RX FRAME DATA BIT DEFINITION**

Packets of compressed speech data are transferred between the processor and Q4401 by the Tx Frame and Rx Frame commands. The number of valid compressed data bits varies based on the data rate. The first byte contains the encoded data rate information. The remaining bytes contain a varying number of valid data bits based on the selected encoded data rate. Figure 12 illustrates the Tx and Rx frame data bit map that the processor follows to extract useful data for transmitting or storing.

**Figure 12. Q4401 Tx and Rx Frame Data Bit Definition**

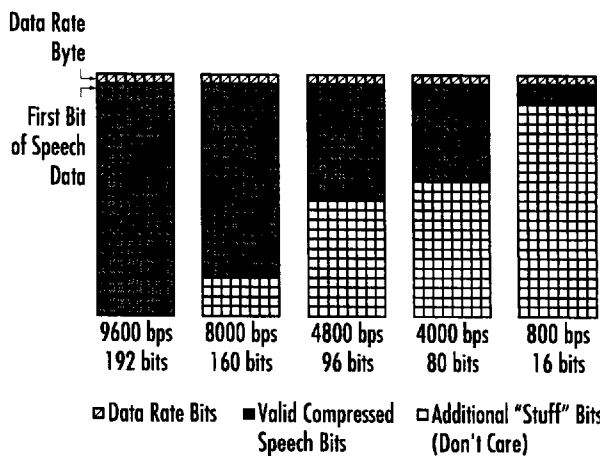

**READ AND WRITE PROTOCOL**

The data transfer protocol between the Q4401 and the processor is governed by the timing requirements stated in this section. Figure 13 shows a pictorial representation of the Read and Write timing requirements.

After the processor initiates a data transfer by writing the length byte of a command packet to the Q4401, the vocoder requires up to 27  $\mu$ s to make a "Write Ready" byte available for the processor to read. During this time interval, the processor continuously reads the Q4401 status until the "Write Ready"

**Figure 13. Packet Transfer Latency**

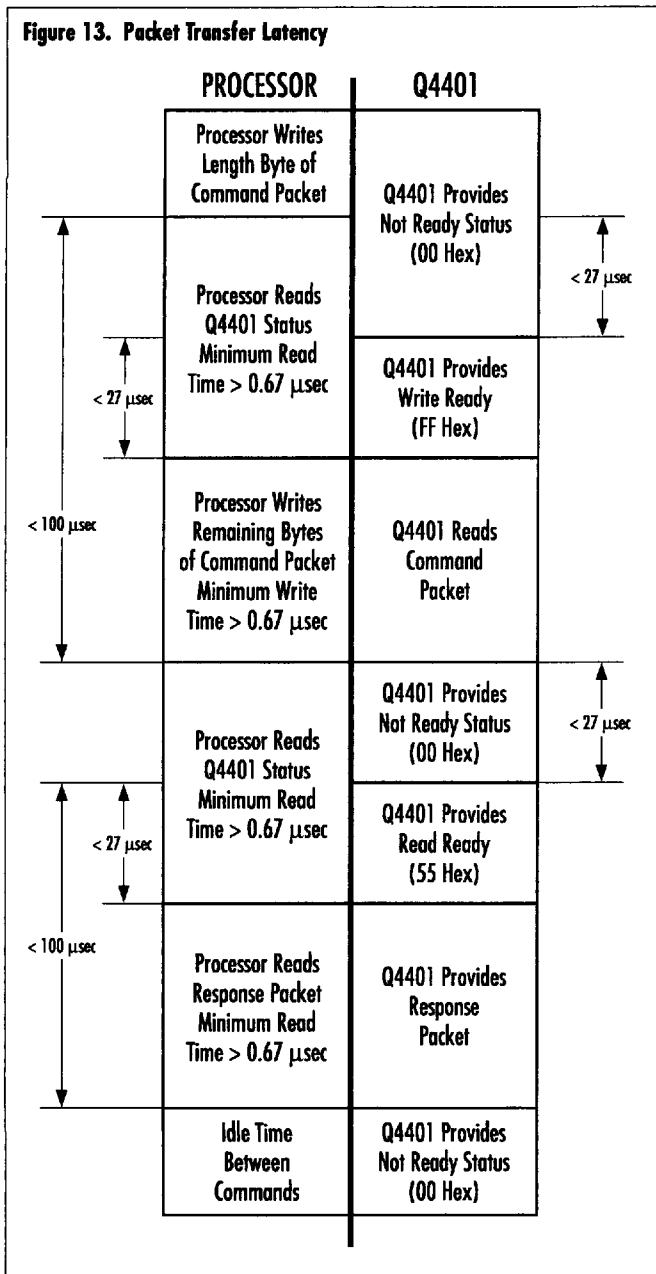

appears. Therefore, the maximum time that it could take for the processor to read the "Write Ready" status is  $27 \mu s + t_r$  (where  $t_r$  is the maximum time interval between successive processor read strobes). The minimum time interval between successive reads from the processor during this time is  $0.67 \mu s$ . The time interval from a Q4401 "Write Ready" to a processor write must not exceed  $27 \mu s$ . Once the processor detects the "Write Ready" status byte, it may consecutively write the remaining bytes in the command packet with a maximum write rate of up to  $0.67 \mu s$  per byte. A typical transfer rate is  $3.0 \mu s$ . The

entire write operation from the length byte to the checksum byte MUST NOT exceed  $100 \mu s$ .

The same requirements hold true for transferring a response packet from the Q4401 to the processor. After the checksum byte of the command packet has been written to the Q4401, the processor must continuously read (minimum time between successive reads is  $0.67 \mu s$ ) the Q4401 until a Read Ready appears. Therefore, the maximum time required for the processor to read the "Read Ready" status is  $27 \mu s + t_r$ . The time interval from a Q4401 "Read Ready" to a processor read must not exceed  $27 \mu s$ . Once the processor detects the "Read Ready" status byte, it may consecutively read all the bytes in the response packet with a maximum read rate up to  $0.67 \mu s$  per byte. The entire read operation from the read ready indication to the checksum byte MUST NOT exceed  $100 \mu s$ .

After the initialization sequence is completed, the Tx Frame and Rx Frame commands are typically input to or output from the Q4401 to perform speech encoding and decoding. A Tx Frame command Write and Read timing example is shown in Figure 14 and an Rx Frame command Write and Read timing example is shown in Figure 15.

Figure 14. Tx Frame Command Timing Example

Tx Frame Command Packet	
Byte 0 = 04	4 Bytes to Follow
Byte 1 = 01	Tx Frame Command
Byte 2 = 04	Highest Frame Rate Allowed
Byte 3 = 01	Lowest Frame Rate Allowed
Byte 4 = 0A	Checksum

Tx Frame Response Packet	
Byte 0 = 1C	28 Bytes to Follow
Byte 1 = 0A	ACK
Byte 2 = 01	Tx Frame
Byte 3 = 04	Tx Frame Rate
Byte 4 to 1B = XX	Tx Frame Data
Byte 1C = XX	Checksum

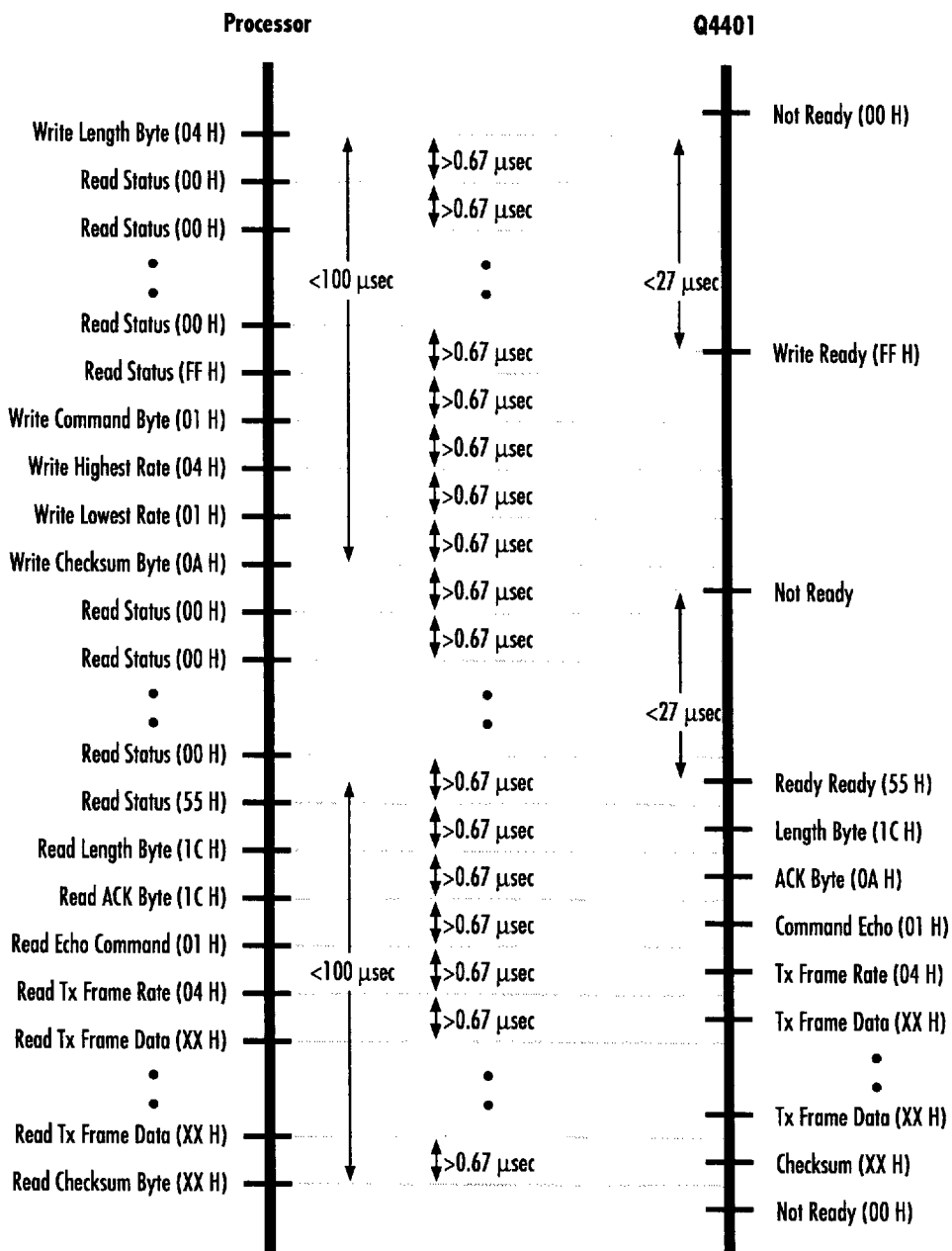

**Figure 15. Rx Frame Command Timing Example**

Rx Frame Command Packet	
Byte 0 = 18	27 Bytes to Follow
Byte 1 = 02	Rx Frame Command
Byte 2 = 04	Rx Frame Rate
Byte 3 to 1A = XX	Rx Frame Data
Byte 4 = 1B = XX	Checksum

Rx Frame Response Packet	
Byte 0 = 03	3 Bytes to Follow
Byte 1 = 0A	ACK
Byte 2 = 02	Rx Frame
Byte 3 = 0F	Checksum

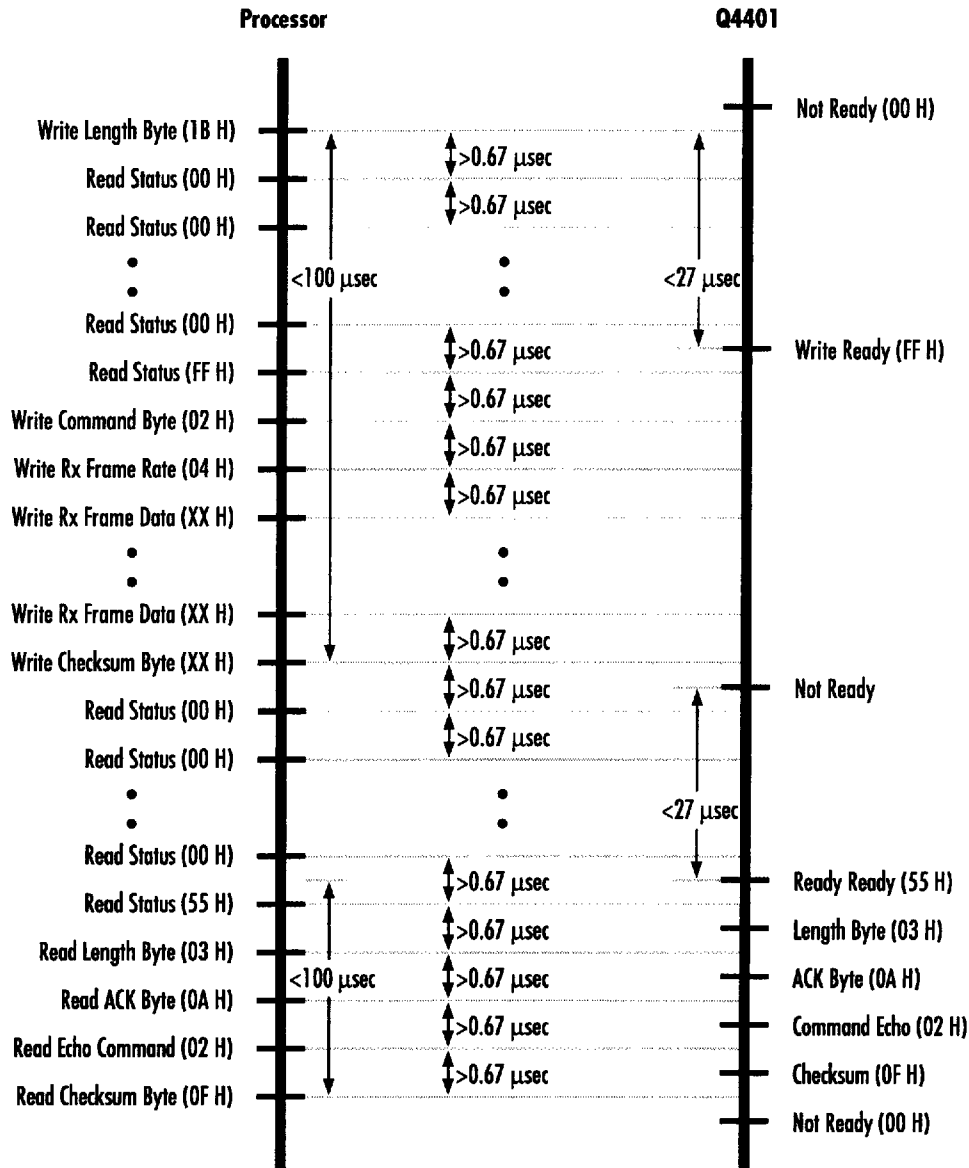

## Q4401 VARIABLE RATE VOCODER COMMANDS

Control of the Q4401 and data transfer to and from the processor is accomplished with a predefined command set and response set. This section describes each command and response to and from the Q4401.

Table 2 provides a summary list of the Q4401

commands and Table 3 provides a summary of responses from the Q4401. Data items that are required for each command are described within the angle brackets. Tables 6 through 23 describe the individual commands and responses.

**Table 2. Q4401 Variable Rate Vocoder Commands**

Command	# of Data Bytes	Command Name and Description
01	2	Tx Frame <Frame Rate for Next Tx Frame>
02	25	Rx Frame <Frame Rate, Frame Data>
03	2	Tx Frame Rate Only <Frame Rate for Next Frame>
04	0	Reserved (Not Used)
05	0	Reserved (Not Used)
06	0	Reinitialize Background Noise Estimate
07	1	Diagnostic Test <Type of Test>
08	0	Sleep Mode (Enter Sleep Mode)
09	11	Voice Operated Switch <VOX Parameters>
0A	2	Initialize <Tx Offset, Rx Offset>
0B	2	Output Volume Control <Output Volume Multiplier>
0C	0	Test Result
0D	8	Tone Generation <Tone Parameter>
0E	1	Input Muting <On or Off>
0F	1	Output Muting <On or Off>
10	2	Advance TX Frame + 1 <Frame Rate for Next Tx Frame> New Tx Offset = Old Tx Offset + 1 (Q4401 Deletes an Input Sample.)
11	2	Slip Tx Frame - 1 <Frame Rate for Next Tx Frame> New Tx Offset = Old Tx Offset - 1 (Q4401 Repeats an Input Sample.)
12	25	Advance Rx Frame + 1 <Frame Rate, Rx Frame Data> New Rx Offset = Old Rx Offset + 1 (Q4401 Repeats an Output Sample.)
13	25	Slip Rx Frame - 1 <Frame Rate, Rx Frame Data> New Rx Offset = Old Rx Offset - 1 (Q4401 Deletes an Output Sample.)
14	2	Average Rate Limit <Rate Limit Flag, Rate Limit Factor>
15	1	Audio Loopback <On or Off>
16	1	Packet Loopback <On or Off>
17	0	Software VRS
18	1	PCM Interface ( $\mu$ -law or A-law)

**Table 3. Q4401 Variable Rate Vocoder Responses**

Command Echo	# of Data Bytes	Response Name and Description
01	25	Tx Frame <Rate, Tx Frame Data>
02	00	Rx Frame Command Received
03	00	Tx Frame Rate Only Command Received
04	0	Reserved (Not Used)
05	0	Reserved (Not Used)
06	0	Background Noise Estimate Reinitialized
07	10	Diagnostic Test Received <Firmware Version #, Time, Date>
08	0	Sleep Mode Command Received
09	0	Voice Operated Switch Command Received
0A	0	Initialize Command Received
0B	0	Output Volume Control Command Received
0C	1	Test Results <Diagnostic Test Result>
0D	0	Tone Generation Command Received
0E	0	Input Muting Command Received
0F	0	Output Muting Command Received
10	25	Tx Frame Advanced by 1 <Rate, Tx Frame Data> New Tx Offset = Old Tx Offset + 1 (Q4401 Deletes an Input Sample.)
11	25	Tx Frame Slipped by 1 <Rate, Tx Frame Data> New Tx Offset = Old Tx Offset - 1 (Q4401 Repeats an Input Sample.)
12	0	Rx Frame Advanced by 1 New Rx Offset = Old Rx Offset + 1 (Q4401 Repeats an Output Sample.)
13	0	Rx Frame Slipped by 1 New Rx Offset = Old Rx Offset - 1 (Q4401 Deletes an Output Sample.)
14	2	Average Rate Limit Command Received
15	0	Audio Loopback Command Received
16	0	Packet Loopback Command Received
17	0	Software VRS Command Received
18	0	PCM Interface Command Received
FF	0	Bad Command Received

**PACKET TRANSFER ERROR CONDITIONS**

If a command packet is received with a bad checksum or if a time-out occurs during the data transfer, the NACK response packet is sent to the processor as shown in Table 4. If a length byte of more than 31 is received, a "Read Ready" is sent to the processor,

followed by a NACK response packet.

If the command packet is received properly, but the Q4401 is unable to process this command (because of unknown commands or missing qualifiers), a "Bad Command" response is sent to the processor as shown in Table 5.

**Table 4. NACK Response Packet**

Byte 0 = 02 (Hex)	2 Bytes to Follow
Byte 1 = 05 (Hex)	NACK
Byte 2 = 07 (Hex)	Checksum

**Table 5. Bad Command Response Packet**

Byte 0 = 03 (Hex)	3 Bytes to Follow
Byte 1 = 0A (Hex)	ACK
Byte 2 = FF (Hex)	Bad Command Received
Byte 3 = 0D (Hex)	Checksum

## TX FRAME COMMAND

Command	01 (hex)
Function	Transfers one packet of compressed speech data from the Q4401 to the processor.
Number of data bytes	Command Packet = 2 Response Packet = 25

### Description

This command orders the Q4401 to transfer a packet of compressed speech data to the processor. The response packet from the Q4401 contains the compressed speech data for the current frame along with a byte containing the specific data rate for the frame. Table 6a and 6b show the Tx Frame command and response packet structures.

The highest and lowest allowable data rates for the next frame to be processed are also embedded in this command. It is with these data rate parameters that the Fixed Rate, Normal Variable Rate, or Enhanced Variable Rate Mode is selected. If one of the Fixed Rate Modes is desired, the highest data rate and lowest data rate bytes will contain the same selection. (Valid Fixed Rate selections are 4000, 4800, 8000, 9600 bps and "Blanked".) The "Blanked" selection will cause a Tx Frame response packet to be transferred with no valid data. This is typically used when a system control packet must be transmitted over the channel in place of a compressed speech data packet. This is required to synchronize the Q4401 at both ends. (Note: the receive side must send the Q4401 a "Blanked" selection, versus an "Erased" selection, upon receiving a system control update.)

The Normal Variable Rate Mode is enabled by selecting 800 bps for the lowest data rate and 8000 bps for the highest data rate. (Valid Normal Variable Rate selections are 800 and 8000 bps, 800 and 4000 bps, or 4000 and 8000 bps.) The Enhanced Variable Rate Mode is enabled by selecting 800 bps for the lowest data rate and 9600 bps for the highest data rate. (Valid Enhanced Variable Rate selections are 800 and 9600 bps, 800 and 4800 bps, or 4800 and 9600 bps.)

This command may be issued any time within a 19 ms window after the Tx Frame Tick. The data rates in this command affect the next 20 ms frame. If new data rates need to be applied to the current frame in process, this command must be issued within a 1 ms window after the Tx Frame Tick. This is described in the *Operational Interfaces* section.

**Table 6a. Tx Frame Command Structure**

Byte #	Value								Description
0	0	0	0	0	0	1	0	0	4 Bytes to Follow (04 Hex)
1	0	0	0	0	0	0	0	1	Tx Frame Command
2	0	0	0	0	N	N	N	N	N = Highest Data Rate
3	0	0	0	0	M	M	M	M	M = Lowest Data Rate
4	C	C	C	C	C	C	C	C	C = 8-bit Checksum

**Table 6b. Tx Frame Response Structure**

Byte #	Value								Description
0	0	0	0	1	1	1	0	0	28 Bytes to Follow (1C Hex)
1	0	0	0	0	1	0	1	0	ACK
2	0	0	0	0	0	0	0	1	Tx Frame Response
3	0	0	0	0	F	F	F	F	F = Data Rate
4 to 1B	X	X	X	X	X	X	X	X	X = Tx Frame Data
1C	C	C	C	C	C	C	C	C	C = 8-bit Checksum

Data Rate Definition:	Value	Description
	00 (Hex)	"Blanked"
	01 (Hex)	800 bps
	03 (Hex)	4000 bps
	04 (Hex)	8000 bps
	0B (Hex)	4800 bps
	0C (Hex)	9600 bps

**Note:** The response packet length will not change for frames that are not full rate. Instead, the unused bytes will contain invalid data.

## RX FRAME COMMAND

Command 02 (hex)

Function Transfers one packet of compressed speech data from the processor to the Q4401.

Number of data bytes Command Packet = 25  
Response Packet = 0

### Description

This command orders the Q4401 to receive a compressed packet of speech data from the processor. The data rate for the packet is also included in this packet. An "Erasure" may be used by the processor when transmission errors are detected. The processor must detect that errors are present within a packet and then issue an "Erasure" to mask the error. The Q4401 estimates what the reconstructed speech will be when an "Erasure" or a "Blanked" selection occur. The "Blanked" selection is discussed in the *Tx Frame Command* section. Tables 7a and 7b show the Rx Frame command and response structures. The response from the Q4401 acknowledges that the command was properly received. This command may be issued any time within a 19 ms window before the Rx Frame Tick.

**Table 7a. Rx Frame Command Structure**

Byte #	Value								Description	
0	0	0	0	0	1	1	0	1	1	27 Bytes to Follow (1B Hex)
1	0	0	0	0	0	0	0	1	0	Rx Frame Command
2	0	0	0	0	F	F	F	F	F	F = Data Rate
3 to 1A	X	X	X	X	X	X	X	X	X	X = Rx Frame Data
1B	C	C	C	C	C	C	C	C	C	C = 8-bit Checksum

**Table 7b. Rx Frame Response Structure**

Byte #	Value								Description	
0	0	0	0	0	0	0	0	1	1	3 Bytes to Follow (03 Hex)
1	0	0	0	0	0	1	0	1	0	ACK
2	0	0	0	0	0	0	0	1	0	Rx Frame Response
3	0	0	0	0	0	1	1	1	1	8-bit Checksum (0F Hex)

Data Rate Definition:	Value	Description
	00 (Hex)	"Blanked"
	01 (Hex)	800 bps
	03 (Hex)	4000 bps
	04 (Hex)	8000 bps
	0B (Hex)	4800 bps
	0C (Hex)	9600 bps
	0E (Hex)	"Erasure"

## TX FRAME RATE ONLY COMMAND

Command 03 (hex)

Function Uses the specified range of data rates for the current frame being processed.

Number of data bytes Command Packet = 2  
Response Packet = 0

### Description

This command changes the data rate parameters of the Encoder without transferring data. This command is used when the data rate for the current frame must change and a Tx Frame command cannot be issued within the required 1 ms window after the Tx Frame Tick. The Tx Frame Rate Only command must be issued within the 1 ms window after the Tx Frame Tick in order for the new data rate ranges to take effect on the current frame. Tables 8a and 8b show the Tx Frame Rate Only command and response structures. The response packet from the Q4401 acknowledges that the command was properly received.

**Table 8a. Tx Frame Rate Only Command Structure**

Byte #	Value								Description
0	0	0	0	0	0	1	0	0	4 Bytes to Follow (04 Hex)
1	0	0	0	0	0	0	1	1	Tx Frame Rate Only Command
2	0	0	0	0	N	N	N	N	N = Highest Data Rate
3	0	0	0	0	M	M	M	M	M = Lowest Data Rate
4	C	C	C	C	C	C	C	C	C = 8-bit Checksum

**Table 8b. Tx Frame Rate Only Response Structure**

Byte #	Value								Description
0	0	0	0	0	0	0	1	1	3 Bytes to Follow (03 Hex)
1	0	0	0	0	1	0	1	0	ACK
2	0	0	0	0	0	0	1	1	Tx Frame Rate Only Response
3	0	0	0	1	0	0	0	0	8-bit Checksum (10 Hex)

Data Rate Definition:	Value	Description
	00 (Hex)	"Blanked"
	01 (Hex)	800 bps
	03 (Hex)	4000 bps
	04 (Hex)	8000 bps
	0B (Hex)	4800 bps
	0C (Hex)	9600 bps

## REINITIALIZE BACKGROUND NOISE ESTIMATE COMMAND

Command 06 (hex)

Function Reinitializes the Q4401 background noise estimate.

Number of data bytes Command Packet = 0  
Response Packet = 0

### Description

This command reinitializes the background noise estimate to optimize the data rate thresholds in the Encoder when Variable Rate Mode is enabled. This command is typically issued at the onset of valid PCM input data to the Q4401. This feature is described in the *Speech Encoding and Decoding* section. Tables 9a and 9b show the Background Noise Estimate command and response structures. The response packet from the Q4401 acknowledges that the command was properly received.

**Table 9a. Reinitialize Background Noise Estimate Command Structure**

Byte #	Value								Description
0	0	0	0	0	0	0	1	0	2 Bytes to Follow (02 Hex)
1	0	0	0	0	0	1	1	0	Reinitialize Bkgd Noise Est Command
2	0	0	0	0	1	0	0	0	8-bit Checksum (08 Hex)

**Table 9b. Reinitialize Background Noise Estimate Response Structure**

Byte #	Value								Description
0	0	0	0	0	0	0	1	1	3 Bytes to Follow (03 Hex)
1	0	0	0	0	1	0	1	0	ACK
2	0	0	0	0	0	1	1	0	Reinitialize Bkgd Noise Est Response
3	0	0	0	1	0	0	1	1	8-bit Checksum (13 Hex)

## DIAGNOSTIC TEST COMMAND

Command 07 (hex)

Function Perform Q4401 self diagnostics.

Number of data bytes Command Packet = 1  
Response Packet = 10

### Description

This command performs an ALU test and a RAM test on the Q4401. Each test is selectable by setting the associated bit in the data word to a "1" as shown in Tables 10a and 10b. The Q4401 will enter the Sleep Mode after completion of these diagnostic tests.

The response packet from the Q4401 acknowledges that the command was properly received along with the firmware version and time. (Note: This response does not contain the diagnostic test results. The diagnostic test results will come from the Get Diagnostic Test Results command.) Tables 10a and 10b show the Diagnostic Test command and response structures.

**Table 10a. Diagnostic Test Command Structure**

Byte #	Value								Description
0	0	0	0	0	0	0	1	1	3 Bytes to Follow (03 Hex)
1	0	0	0	0	0	1	1	1	Diagnostic Test Command
2	0	0	0	0	0	M1	M2	0	Type of Tests. M1 = ALU, M2 = RAM
3	C	C	C	C	C	C	C	C	C = 8-bit Checksum

**Table 10b. Diagnostic Test Response Structure**

Byte #	Value								Description
0	0	0	0	0	1	1	0	1	13 Bytes to Follow (0D Hex)
1	0	0	0	0	1	0	1	0	ACK
2	0	0	0	0	0	1	1	1	Diagnostic Test Response
3	X	X	X	X	X	X	X	X	Firmware Version (Major Rev #)
4	X	X	X	X	X	X	X	X	Firmware Version (Major Rev #)
5 to 7	X	X	X	X	X	X	X	X	Time Minutes after 00:00 Jan. 6, 1980
8 to 0C	0	0	0	0	0	0	0	0	Reserved Bytes (All 5 Bytes = 00 Hex)
0D	C	C	C	C	C	C	C	C	C = 8-bit Checksum

## SLEEP MODE COMMAND

Command	08 (hex)
Function	Commands the Q4401 to enter sleep mode.
Number of data bytes	Command Packet = 0 Response Packet = 0

### Description

This command orders the Q4401 perform a software reset, enter Sleep Mode, and then wait for an Initialize command from the processor. Sleep Mode may be entered to conserve power when there is no requirement for speech compression. Tables 11a and 11b show the Sleep Mode command and response structures. The response packet from the vocoder acknowledges that the command was properly received.

**Table 11a. Sleep Mode Command Structure**

Byte #	Value								Description
0	0	0	0	0	0	0	1	0	2 Bytes to Follow (02 Hex)
1	0	0	0	0	1	0	0	0	Sleep Mode Command
2	0	0	0	0	1	0	1	0	8-bit Checksum (0A Hex)

**Table 11b. Sleep Mode Response Structure**

Byte #	Value								Description
0	0	0	0	0	0	0	1	1	3 Bytes to Follow (03 Hex)
1	0	0	0	0	1	0	1	0	ACK
2	0	0	0	0	1	0	0	0	Sleep Mode Response
3	0	0	0	1	0	1	0	1	8-bit Checksum (15 Hex)

## VOX COMMAND

Command

09 (hex)

Function

Enables or Disable the VOX function.

Number of data bytes

Command Packet = 11

Response Packet = 0

### Description

This command enables or disables the VOX function and configures the VOX parameters. The VOX function is enabled when hands free telephone operation is required. The VOX feature is described in the *Operational Modes* section. Tables 12a and 12b show the VOX command and response structures and Table 12c shows the VOX parameters. The response packet from the Q4401 acknowledges that the command was properly received.

**Table 12a. VOX Command Structure**

Byte #	Value								Description
0	0	0	0	0	1	1	0	1	13 Bytes to Follow (0D Hex)
1	0	0	0	0	1	0	0	1	VOX Mode Command
2	0	0	0	0	0	0	0	X	X = VOX Enable or Disable 1 = Enable 00 = Disable
3	X	X	X	X	X	X	X	X	Energy Decay Factor MS Byte
4	X	X	X	X	X	X	X	X	Energy Decay Factor LS Byte
5	X	X	X	X	X	X	X	X	Background Noise Decay Factor MS Byte
6	X	X	X	X	X	X	X	X	Background Noise Decay Factor LS Byte
7	X	X	X	X	X	X	X	X	Decoder Background Noise MS Byte
8	X	X	X	X	X	X	X	X	Decoder Background Noise LS Byte
9	X	X	X	X	X	X	X	X	Decoder VOX Threshold MS Byte
A	X	X	X	X	X	X	X	X	Decoder VOX Threshold LS Byte
B	X	X	X	X	X	X	X	X	Encoder Weighting Factor MS Byte
C	X	X	X	X	X	X	X	X	Encoder Weighting Factor LS Byte
D	C	C	C	C	C	C	C	C	C = 8-bit Checksum

**Table 12b. VOX Response Structure**

Byte #	Value								Description
0	0	0	0	0	0	0	1	1	3 Bytes to Follow (03 Hex)
1	0	0	0	0	1	0	1	0	ACK
2	0	0	0	0	1	0	0	1	VOX Mode Response
3	0	0	0	1	0	1	1	0	8-bit Checksum (16 Hex)

**Table 12c. VOX Parameters**

Parameter	Description
Enable/Disable	0 = Disable 1 = Enable
Energy Decay Factor <MS Byte, LS Byte>	Reasonable values are between 0.5 and 1.0. Typical value is 0.875. This value must be multiplied by $2^{14}$ to get the correct parameter for the VOX command. ( $2^{14} \times 0.875 = 14336 \Rightarrow 3800$ hex). The Energy Decay factor is used to keep the VOX Mode from disabling the near-end speaker during pauses between words and syllables. This parameter allows the user to select the speech energy decay time.
Background Noise Decay Factor <MS Byte,LS Byte>	Reasonable values are between 1.0 and 1.2. Typical value is 1.01. This value must be multiplied by $2^{14}$ to get the correct parameter for the VOX command. ( $2^{14} \times 1.01 = 16548 \Rightarrow 40A4$ hex). This parameter determines how fast the background noise estimate is allowed to increase.
Decoder Background Noise Floor <MS Byte, LS Byte>	Typical value is 40. This value must be multiplied by 4 to get the correct parameter for the VOX command. ( $4 \times 40 = 160 \Rightarrow 00A0$ hex). This parameter limits how low the Decoder background noise is allowed to drop. VOX Mode does not work efficiently if the Decoder background noise goes below a certain level.
Decoder VOX Threshold <MS Byte, LS Byte>	Typical value is 6dB. This value must be multiplied by $2^8$ to get the correct parameter for the VOX command. ( $2^8 \times 4.0 = 1024 \Rightarrow 0400$ hex). If the far-end speaker energy is less than 6 dB above the Decoder's background noise, then there is no need for echo suppression, and the VOX Mode stays in the idle state.
Encoder Weighting Factor <MS Byte, LS Byte>	Typical value is 0. This value must be multiplied by $2^8$ to get the correct parameter for the VOX command. ( $2^8 \times 0 = 0 \Rightarrow 0000$ hex). The Encoder's energy is weighted by this parameter to allow switching to be varied on the relative loudness of the two speakers. For typical conversations, it has been found that good performance is obtained by settling this parameter to zero so that the far-end speaker has complete priority. Settling this parameter to a fractional amount will allow the near-end speaker to interrupt the far-end speaker by speaking loudly. It is not recommended to set this parameter to values above one because parts of speech may be cut out due to noise in the environment.

## INITIALIZE COMMAND

Command 0A (hex)

Function Sets the Tx Offset and Rx Offset and instructs the Q4401 to look for the VRS.

Number of data bytes Command Packet = 2  
Response Packet = 0

### Description

The Initialize command sets the Q4401 Tx Offset and Rx Offset (Frame Timing). The two data bytes specify the relative timing of the Tx Frame Tick and the Rx Frame Tick to the VRS. This command resets the memory inside the Q4401. Therefore, this command should not be used a second time without ensuring that the Q4401 on the other end (if the application has one) is at the same reset state as well. Tables 13a and 13b show the Initialize command and response structures and Table 13c shows the Tx/Rx Offset Parameters. The response packet from the Q4401 acknowledges that the command was properly received.

**Table 13a. Initialize Command Structure**

Byte #	Value								Description
0	0	0	0	0	0	1	0	0	4 Bytes to Follow (04 Hex)
1	0	0	0	0	1	0	1	0	Initialize Command
2	X	X	X	X	X	X	X	X	Tx Offset (0 to A0 (160 Samples))
3	X	X	X	X	X	X	X	X	Rx Offset (0 to 0A (160 Samples))
4	C	C	C	C	C	C	C	C	C = 8-bit Checksum

**Table 13b. Initialize Response Structure**

Byte #	Value								Description
0	0	0	0	0	0	0	1	1	3 Bytes to Follow (03 Hex)
1	0	0	0	0	1	0	1	0	ACK
2	0	0	0	0	1	0	1	0	Initialize Response
3	0	0	0	1	0	1	1	1	8-bit Checksum (17 Hex)

**Table 13c. Tx/Rx Offset Parameters**

Parameter	Description
Tx Offset	Sets the time from VRS to the Tx Frame Tick. This value represents the number of PCM samples (125 ms) from VRS to the Tx Frame Tick.
Rx Offset	Sets the time from VRS to the Rx Frame Tick. This value represents the number of PCM samples (125 ms) from VRS to the Rx Frame Tick.

## OUTPUT VOLUME CONTROL COMMAND

Command	0B (hex)
Function	Sets output volume.
Number of data bytes	Command Packet = 2 Response Packet = 0

### Description

This command controls the Q4401 output volume. The volume control multiplier is in the linear domain. It consists of a 16-bit word with eight fractional bits (i.e., 0100 represents unity gain; 0200 is two times; and 0080 is 1/2). Tables 14a and 14b show the Output Volume Control command and response structures. The response packet from the Q4401 acknowledges that the command was properly received.

**Table 14a. Output Volume Control Command Structure**

Byte #	Value								Description
0	0	0	0	0	0	1	0	0	4 Bytes to Follow (04 Hex)
1	0	0	0	0	1	0	1	1	Output Volume Control Command
2	X	X	X	X	X	X	X	X	Output Volume Multiplier MS Byte
3	X	X	X	X	X	X	X	X	Output Volume Multiplier LS Byte
4	C	C	C	C	C	C	C	C	C = 8-bit Checksum

**Table 14b. Output Volume Control Response Structure**

Byte #	Value								Description
0	0	0	0	0	0	0	1	1	3 Bytes to Follow (03 Hex)
1	0	0	0	0	1	0	1	0	ACK
2	0	0	0	0	1	0	1	1	Output Volume Control Response
3	0	0	0	1	1	0	0	0	8-bit Checksum (18 Hex)

**Control Parameters: 16-bit Volume Control Multiplier Word**

## TEST RESULT COMMAND

Command 0C (hex)

Function Transfers diagnostic test results from the Q4401 to the processor.

Number of data bytes Command Packet = 0  
Response Packet = 1

### Description

This command sends the diagnostic test result to the processor. The test result byte provided in the response packet contains a bit indicating that the test result is ready and 3 bits indicating the results of the two tests (RAM, and ALU). Each bit is set to "1" if the test passed and "0" if the test failed. Tables 15a and 15b show the Test Result command and response structures.

**Table 15a. Test Result Command Structure**

Byte #	Value								Description
0	0	0	0	0	0	0	1	0	2 Bytes to Follow (02 Hex)
1	0	0	0	0	1	1	0	0	Test Result Command
2	0	0	0	0	1	1	1	0	8-bit Checksum (0E Hex)

**Table 15b. Test Result Response Structure**

Byte #	Value								Description
0	0	0	0	0	0	1	0	0	4 Bytes to Follow (04 Hex)
1	0	0	0	0	1	0	1	0	ACK
2	0	0	0	0	1	1	0	0	Test Result Response
3	R	0	0	0	0	M1	M2	1	Test Result: R = Result Ready (1 = Ready) M1 = ALU, M2 = RAM (1 = Passed)
4	C	C	C	C	C	C	C	C	C = 8-bit Checksum

## tone generation command

Command	0D (hex)
Function	Performs tone generation.
Number of data bytes	Command Packet = 8 Response Packet = 0

### Description

This command enables or disables and configures the Tone Generation feature of the Q4401. Single tones or DTMF tones may be generated by providing the frequency, volume, and duration parameters. The Q4401 continues operating during tone generation; thus, received packets must continue to be passed to the Q4401 even though tone generation overrides voice output. The Q4401 must receive the Initialize command before tone generation can occur. Sending this command a second time with new frequencies while tones are being generated will cause all parameters to be overwritten and an instantaneous change in output frequency will occur. However, sending this command again with the same frequencies results in no change in phase of the output tones. This allows the duration to be extended by sending multiple commands. Tables 16a and 16b show the Tone Generation command and response structures and Table 16c shows the Tone Generation parameters. The response packet from the Q4401 acknowledges that the command was properly received.

**Table 16a. Tone Generation Command Structure**

Byte #	Value								Description
0	0	0	0	0	1	0	1	0	10 Bytes to Follow (0A Hex)
1	0	0	0	0	1	1	0	1	Tone Generation Command
2	X	X	X	X	X	X	X	X	F1 Tone MS Byte
3	X	X	X	X	X	X	X	X	F1 Tone LS Byte
4	X	X	X	X	X	X	X	X	F2 Tone MS Byte
5	X	X	X	X	X	X	X	X	F2 Tone LS Byte
6	X	X	X	X	X	X	X	X	Volume Tone MS Byte
7	X	X	X	X	X	X	X	X	Volume Tone LS Byte
8	X	X	X	X	X	X	X	X	Duration MS Byte
9	X	X	X	X	X	X	X	X	Duration LS Byte
A	C	C	C	C	C	C	C	C	C = 8-bit Checksum

**Table 16b. Tone Generation Response Structure**

Byte #	Value								Description
0	0	0	0	0	0	0	1	1	3 Bytes to Follow (03 Hex)
1	0	0	0	0	1	0	1	0	ACK
2	0	0	0	0	1	1	0	1	Tone Generation Response
3	0	0	0	1	1	0	1	0	8-bit Checksum (1A Hex)





### ADVANCE TX FRAME +1 COMMAND

Command 10 (hex)

Function Transfers one packet of compressed speech data from the Q4401 to the processor and advances Tx timing by 1 sample.

Number of data bytes Command Packet = 2  
Response Packet = 25

#### Description

This command orders the Q4401 to transfer a packet of compressed speech data to the processor while advancing the Tx Frame Tick by one sample. Otherwise, this command is identical to the Tx Frame command. This command is used in place of the Tx Frame command. Refer to the *Tx Frame Command* in this section for additional information and for the command and response structures.

### SLIP TX FRAME -1 COMMAND

Command 11 (hex)

Function Transfers one packet of compressed speech data from the Q4401 to the processor and slips Tx timing by 1 sample.

Number of data bytes Command Packet = 2  
Response Packet = 25

#### Description

This command orders the Q4401 to transfer a packet of compressed speech data to the processor while slipping the Tx Frame Tick by one sample. Otherwise, this command is identical to the Tx Frame command. This command is used in place of the Tx Frame command. Refer to the *Tx Frame Command* in this section for additional information and for the command and response structures.

### ADVANCE RX FRAME +1 COMMAND

Command 12 (hex)

Function Transfers one packet of compressed speech data from the processor to the Q4401 and advances Rx timing by 1 sample.

Number of data bytes Command Packet = 25  
Response Packet = 0

#### Description

This command orders the Q4401 to receive a packet of compressed speech data from the processor while advancing the Rx Frame Tick by one sample. Otherwise, this command is identical to the Rx Frame command. This command is used in place of the Rx Frame command. Refer to the *Rx Frame command* in this section for additional information and for the command and response structures.

### SLIP RX FRAME -1 COMMAND

Command 13 (hex)

Function Transfers one packet of compressed speech data from the processor to the Q4401 and slips Rx timing by 1 sample.

Number of data bytes Command Packet = 25  
Response Packet = 0

#### Description

This command orders the Q4401 to receive a packet of compressed speech data from the processor while slipping the Rx Frame Tick by one sample. Otherwise, this command is identical to the Rx Frame command. This command is used in place of the Rx Frame command. Refer to the *Rx Frame command* in this section for additional information and for the command and response structures.

## AVERAGE RATE LIMIT COMMAND

Command	14 (hex)
Function	Limit the average data rate of the Q4401.
Number of data bytes	Command Packet = 2 Response Packet = 0

### Description

This command limits the maximum average data rate of the Q4401 Encoder. The average maximum limit is selectable between half and full rates. The average rate is programmed by selecting a rate factor value along with one of the Variable Rate Modes of operation. For example, if "S" = 1 and Normal Variable Rate is selected, the average rate of  $\frac{3}{4}$  is equal to 6000 bps. If Enhanced Variable Rate is selected, the maximum average rate of  $\frac{3}{4}$  is equal to 7200 bps. If "S" =  $\frac{1}{2}$  (by setting bit 1 of the Rate Flag to 0 and the Rate Factor to 2), the maximum average rate is  $\frac{2}{3}$ . Tables 19a and 19b show the Average Rate Limit command and response structures and Table 19c shows the Average Rate Limit Parameters. The response packet from the Q4401 acknowledges that the command was properly received.

**Table 19a. Average Rate Limit Command Structure**

Byte #	Value								Description
0	0	0	0	0	0	1	0	0	4 Bytes to Follow (04 Hex)
1	0	0	0	1	0	1	0	0	Average Rate Limit Command
2	0	0	0	0	0	0	R1	R0	Rate Limit Flag (See Table 19c.)
3	X	X	X	X	X	X	X	X	Rate Limit Factor (See Table 19c.)
4	C	C	C	C	C	C	C	C	C = 8-bit Checksum

**Table 19b. Average Rate Limit Response Structure**

Byte #	Value								Description
0	0	0	0	0	0	0	1	1	3 Bytes to Follow (03 Hex)
1	0	0	0	0	1	0	1	0	ACK
2	0	0	0	1	0	1	0	0	Average Rate Limit Response
3	0	0	1	0	0	0	0	1	8-bit Checksum (21 Hex)

**Table 19c. Average Rate Limit Parameters**

Parameter	Description
Rate Limit Flag	Bit R0 1 = Enable Average Rate Limit 0 = Disable Average Rate Limit
	Bit R1 1 = "S" = Rate Limit Factor 0 = "S" = 1/Rate Limit Factor
Rate Limit Factor	An 8-bit Unsigned Integer The maximum average rate of the Q4401 is equal to $(2S + 1)/(2(S + 1))$ .

## AUDIO LOOP BACK COMMAND

Command 15 (hex)

Function Enables Audio Loop Back Mode.

Number of data bytes Command Packet = 1  
Response Packet = 0

### Description

This commands the Q4401 to loop back the PCM samples from the Encoder's input to the Decoder's output. Tables 20a and 20b show the Audio Loop Back command and response structures. The response packet from the Q4401 acknowledges that the command was properly received.

**Table 20a. Audio Loop Back Command Structure**

Byte #	Value								Description
0	0	0	0	0	0	0	1	1	3 Bytes to Follow (03 Hex)
1	0	0	0	1	0	1	0	1	Audio Loop Back Command
2	0	0	0	0	0	0	0	X	1 = Enable 0 = Disable
3	C	C	C	C	C	C	C	C	C = 8-bit Checksum

**Table 20b. Audio Loop Back Response Structure**

Byte #	Value								Description
0	0	0	0	0	0	0	1	1	3 Bytes to Follow (03 Hex)
1	0	0	0	0	1	0	1	0	ACK
2	0	0	0	1	0	1	0	1	Audio Loop Back Response
3	0	0	1	0	0	0	1	0	8-bit Checksum (22 Hex)

## PACKET LOOP BACK COMMAND

Command 16 (hex)

Function Enables Packet Loop Back Mode.

Number of data bytes Command Packet = 1  
Response Packet = 0

### Description

This commands the Q4401 to loop back the Rx packets as Tx packets to the processor. Tables 21a and 21b shows the Packet Loop Back command and response structures. The response packet from the Q4401 acknowledges that the command was properly received.

**Table 21a. Packet Loop Back Command Structure**

Byte #	Value								Description	
0	0	0	0	0	0	0	0	1	1	3 Bytes to Follow (03 Hex)
1	0	0	0	1	0	1	1	0		Packet Loop Back Command
2	0	0	0	0	0	0	0	X		1 = Enable 0 = Disable
3	C	C	C	C	C	C	C	C	C	C = 8-bit Checksum

**Table 21b. Packet Loop Back Response Structure**

Byte #	Value								Description	
0	0	0	0	0	0	0	0	1	1	3 Bytes to Follow (03 Hex)
1	0	0	0	0	1	0	1	0		ACK
2	0	0	0	1	0	1	1	0		Packet Loop Back Response
3	0	0	1	0	0	0	1	1		8-bit Checksum (23 Hex)

## SOFTWARE VRS COMMAND

Command 17 (hex)

Function Replaces the external reference strobe function.

Number of data bytes Command Packet = 0  
Response Packet = 0

### Description

This command may be used instead of the hardware VRS input. This command may be issued one time after the Initialize command has been issued to establish the Tx Frame and Rx Frame timing. Tables 22a and 22b show the Software VRS command and response structures. The response packet from the Q4401 acknowledges that the command was properly received.

**Table 22a. Software VRS Command Structure**

Byte #	Value								Description
0	0	0	0	0	0	0	1	0	2 Bytes to Follow (02 Hex)
1	0	0	0	1	0	1	1	1	Software VRS Command
2	0	0	0	1	1	0	0	1	8-bit Checksum (19 Hex)

**Table 22b. Software VRS Response Structure**

Byte #	Value								Description
0	0	0	0	0	0	0	1	1	3 Bytes to Follow (03 Hex)
1	0	0	0	0	1	0	1	0	ACK
2	0	0	0	1	0	1	1	1	Software VRS Response
3	0	0	1	0	0	1	0	0	8-bit Checksum (24 Hex)

**PCM INTERFACE COMMAND**

Command 18 (hex)

Function Selects either m-Law or A-Law Interface.

Number of data bytes Command Packet = 1  
Response Packet = 0

**Description**

This command selects either a  $\mu$ -Law interface or an A-Law interface. The default interface is the  $\mu$ -Law interface if this command is not issued. If the  $\mu$ -Law interface is selected then a  $\mu$ -Law codec must be used. If the A-Law interface is selected then an A-Law codec must be used. This command must be issued after the Initialize command. Tables 23a and 23b show the PCM Interface command and response structures. The response packet from the Q4401 acknowledges that the command was properly received.

**Table 23a. PCM Interface Command Structure**

Byte #	Value								Description
0	0	0	0	0	0	0	1	1	3 Bytes to Follow (03 Hex)
1	0	0	0	1	1	0	0	0	PCM Interface Command
2	0	0	0	0	0	0	0	N	$\mu$ -Law = 0 A-Law = 1
3	C	C	C	C	C	C	C	C	C = 8-bit Checksum

**Table 23b. PCM Interface Response Structure**

Byte #	Value								Description
0	0	0	0	0	0	0	1	1	3 Bytes to Follow (03 Hex)
1	0	0	0	0	1	0	1	0	ACK
2	0	0	0	1	1	0	0	0	PCM Interface Response
3	0	0	1	0	0	1	0	1	8-bit Checksum (25 Hex)

## TECHNICAL SPECIFICATIONS

### PIN DESCRIPTIONS (PQFP PACKAGE)

Following are the functions and operations of the input and output pins of the Q4401 in the PQFP package.

Figure 16 shows the location of the pins; Table 24 describes the function of each pin.

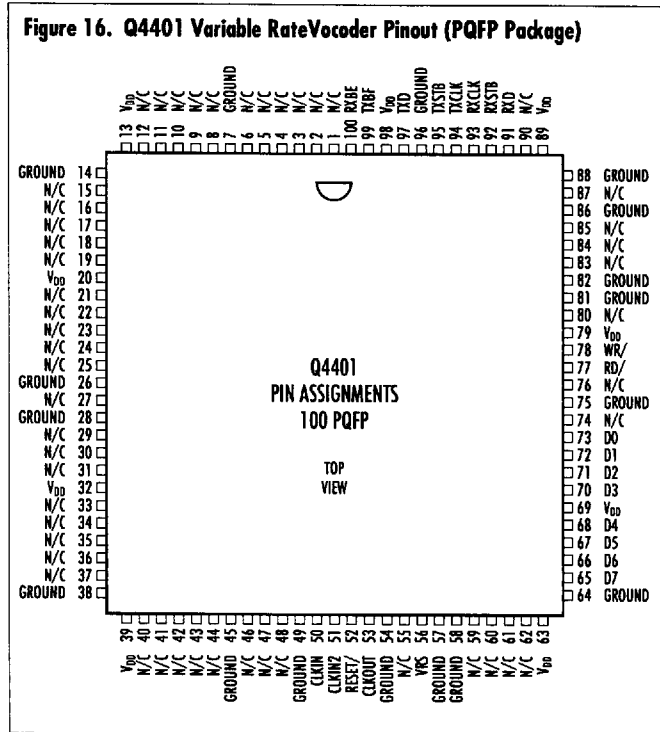

**Table 24. Q4401 Variable Rate Vocoder Pin Functions (PQFP Package)**

Name	Pins	Type	Function
CLKIN	50	Input	Clock input for CMOS clock or crystal input. Use 10 pF cap to V <sub>SS</sub> for crystal input.
CLKIN2	51	Input	Other clock input for crystal input. Use 10 pF cap to V <sub>SS</sub> for crystal input. Leave open for CMOS clock.
RESET/	52	Input	Q4401 Reset (Active Low)
CLKOUT	53	Output	Q4401 Clock Output
VRS	56	Input	Vocoder Reference Strobe
D7 - D0	65, 66, 67, 68, 70, 71, 72, 73	Input/Output	CPU Data Bus Interface Pin 65 is the MSB
RD/	77	Input	Output Data Strobe
WR/	78	Input	Input Data Strobe
RXD	91	Output	PCM Data Output
RXSTB	92	Input	PCM Output Load (8 kHz)
RXCLK	93	Input	PCM Output Clock
TXCLK	94	Input	PCM Input Clock
TXSTB	95	Input	PCM Input Load (8kHz)
TXD	97	Input	PCM Data Input
TXBF	99	Output	PCM Input Buffer Full
RXBE	100	Output	PCM Output Buffer Empty
V <sub>DD</sub>	13, 20, 32, 39, 63, 69, 79, 89, 98	Power	+5 Volt Power
V <sub>SS</sub>	7, 14, 26, 28, 38, 45, 49, 54, 57, 58, 64, 75, 81, 82, 86, 88, 96	Ground	Digital Ground
N/C	1-6, 8-12, 15-19, 21-25, 27, 29-31, 33-37, 40-44, 46-48, 55, 59-62, 74, 76, 80, 83-85, 87, 90	Unused	Make no connection to these pins.

## PIN DESCRIPTIONS (TQFP PACKAGE)

Following are the functions and operations of the input and output pins of the Q4401 in the TQFP package.

Figure 17 shows the location of the pins; Table 25 describes the function of each pin.

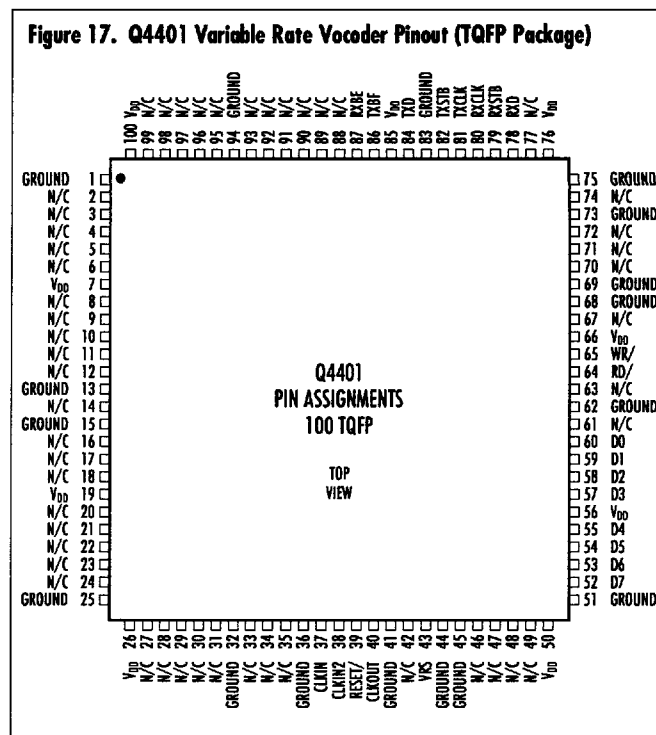

**Table 25. Q4401 Variable rate Vocoder Pin Functions (TQFP Package)**

Name	Pins	Type	Function
CLKIN	37	Input	Clock input for CMOS clock or crystal input. Use 10 pF cap to VSS for crystal input.
CLKIN2	38	Input	Other clock input for crystal input. Use 10 pF cap to VSS for crystal input. Leave open for CMOS clock.
RESET/	39	Input	Q4401 Reset (Active Low)
CLKOUT	40	Output	Q4401 Clock Output
VRS	43	Input	Vocoder Reference Strobe
D7 - D0	52, 53, 54, 55, 57, 58, 59, 60	Input/Output	CPU Data Bus Interface Pin 52 is the MSB
RD/	64	Input	Output Data Strobe
WR/	65	Input	Input Data Strobe
RXD	78	Output	PCM Data Output
RXSTB	79	Input	PCM Output Load (8 kHz)
RXCLK	80	Input	PCM Output Clock
TXCLK	81	Input	PCM Input Clock
TXSTB	82	Input	PCM Input Load (8kHz)
TXD	84	Input	PCM Data Input
TXBF	86	Output	PCM Input Buffer Full
RXBE	87	Output	PCM Output Buffer Empty
VDD	7, 19, 26, 50, 56, 66, 76, 85, 100	Power	+5 Volt Power
VSS	1, 13, 15, 25, 32, 36, 41, 44, 45, 51, 62, 68, 69, 73, 75, 83, 94	Ground	Digital Ground
N/C	2-6, 8-12, 14, 16-18, 20-24, 27-31, 33-35, 42, 46-49, 61, 63, 67, 70-72, 74, 77, 88-93, 95-99	Unused	Make no connection to these pins.

## ELECTRICAL SPECIFICATIONS

### ABSOLUTE MAXIMUM RATINGS

Table 26 provides the absolute maximum rating for the Q4401. Stresses above those listed under "Absolute Maximum Ratings" may cause permanent damage to the device. These are stress ratings only and functional

operation of the device at these or any other conditions above those indicated in the operational sections of this specification is not implied. Exposure to absolute maximum rating conditions for extended periods may affect device reliability.

**Table 26. Absolute Maximum Ratings**

PARAMETER	SYMBOL	MIN	MAX	UNITS
Storage Temperature	$T_S$	-65	+150	$^{\circ}\text{C}$
Operating Temperature	$T_A$	-40	+85	$^{\circ}\text{C}$
Junction Temperature	$T_J$	-	+125	$^{\circ}\text{C}$
Voltage on Any Input Pin	-	-0.5	+5.75	V

### DC ELECTRICAL CHARACTERISTICS

Table 27 shows the DC electrical characteristics for the Q4401.

**Table 27. DC Electrical Performance Characteristics**

PARAMETER	SYMBOL	MIN	MAX	UNITS	NOTES
Supply Voltage	$V_{DD}$	4.75	5.25	V	-
High-level Input Voltage (Non-clock Inputs)	$V_{IH}$	$0.7 \times V_{DD}$	-	V	-
Low-level Input Voltage (Non-clock Inputs)	$V_{IL}$	-	$0.3 \times V_{DD}$	V	-
Clock High-level Input Voltage (CMOS Input)	$V_{IH}$	$0.7 \times V_{DD}$	-	V	-
Clock Low-level Input Voltage (CMOS Input)	$V_{IL}$	-	$0.3 \times V_{DD}$	V	-
Frequency of Fundamental Mode Crystal	$F_X$	-	30	MHz	-
Series Resistance of Fundamental Mode Crystal (pins: CLKIN, CLKIN2)	$R_S$	-	40	$\Omega$	-
Mutual Capacitance of Fundamental Mode Crystal	$C_D$	-	7	pF	-
Input Current	$I_{IL}$	-5	-	$\mu\text{A}$	-
	$I_{IH}$	-	5	$\mu\text{A}$	-
High-level Output Voltage	$V_{OH}$	$V_{DD} - 0.7$	-	V	$I_{OH} = -2.0 \text{ mA}$
	$V_{OH}$	$V_{DD} - 0.2$	-	V	$I_{OH} = -50 \mu\text{A}$
Low-level Output Voltage	$V_{OL}$	-	0.4	V	$I_{OL} = 2.0 \text{ mA}$
	$V_{OL}$	-	0.2	V	$I_{OL} = 50 \mu\text{A}$
Output Tri-state Current	$I_{OZL}$	-10	-	$\mu\text{A}$	-
	$I_{OZH}$	-	+10	$\mu\text{A}$	-
Input Capacitance	$C_I$	-	10	pF	-
Power Dissipation (Active Mode)	$P_D$	-	425	mW	$V_{DD} = 5.0 \text{ V}$ $F_X = 30 \text{ MHz}$
Power Dissipation (Sleep Mode)	$P_D$	-	45	mW	$V_{DD} = 5.0 \text{ V}$ $F_X = 30 \text{ MHz}$

## TIMING CHARACTERISTICS

Figures 18 - 25 and Tables 28 - 35 provide the timing specifications for the Q4401. These specifications are valid only for the following conditions:

$T_A = -40\text{ }^\circ\text{C}$  to  $+85\text{ }^\circ\text{C}$

$V_{DD} = 5\text{ V} \pm 5\%$ ,  $V_{SS} = 0\text{ V}$

Capacitance Load on Outputs ( $C_L$ ) = 50 pF

**Figure 18. Q4401 Variable Rate Vocoder Clock Timing Diagram**

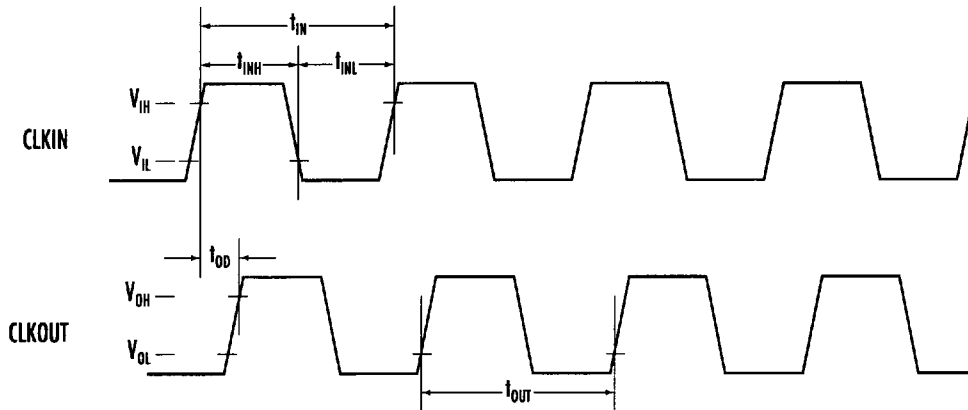

**Table 28. Q4401 Variable Rate Vocoder Clock Timing Parameters**

PARAMETER	SYMBOL	MIN	MAX	UNITS
CLKIN Period (High to High)	$t_{IN}$	33	—	ns
CLKIN Low Time (Low to High)	$t_{IL}$	15	—	ns
CLKIN High Time (High to Low)	$t_{IH}$	15	—	ns
CLKOUT Delay (High to High)	$t_{OD}$	—	21	ns
CLKOUT Period (Low to Low)	$t_{OUT}$	$t_{IN}$	—	ns

**Figure 19. Reset Timing Diagram**

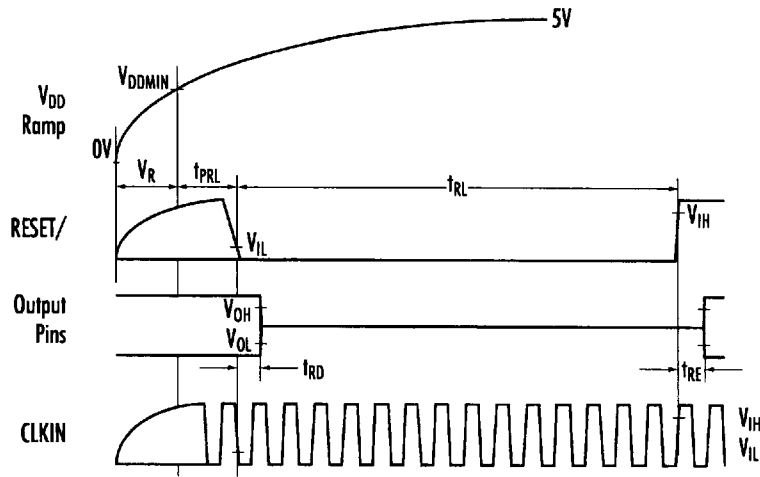
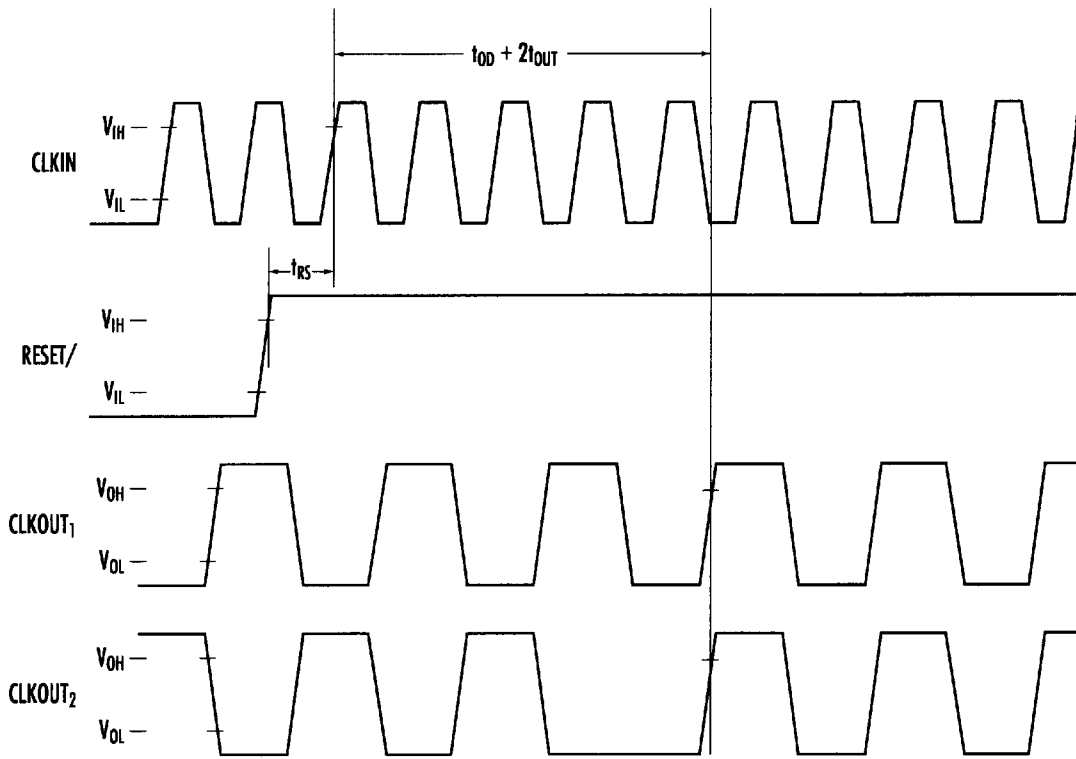

**Table 29. Reset Timing Parameters**

PARAMETER	SYMBOL	MIN	MAX	UNITS
Power On to RESET Low	$t_{PRL}$	20	—	ms
Reset Pulse (Low to High)	$t_{RL}$	6T*	—	ns
$V_{DD}$ Ramp	$V_R$	—	10	ms
RESET Disable Time (Low to Tri-state)	$t_{RD}$	—	100	ns
RESET Enable Time (High to Valid)	$t_{RE}$	—	100	ns

\*T =  $t_{IH}$

**Figure 20. Reset Synchronization Timing Diagram**



Note: CLKOUT<sub>1</sub> and CLKOUT<sub>2</sub> are two possible CLKOUT states before RESET/. CLKOUT is free-running.

**Table 30. Reset Synchronization Timing Parameters**

PARAMETER	SYMBOL	MIN	MAX	UNITS
Reset Setup (High to High)	$t_{RS}$	4	$T/2 - 5^*$	ns

\* $T = t_{IH}$

**Figure 21. Vocoder Reference Strobe Timing Diagram**

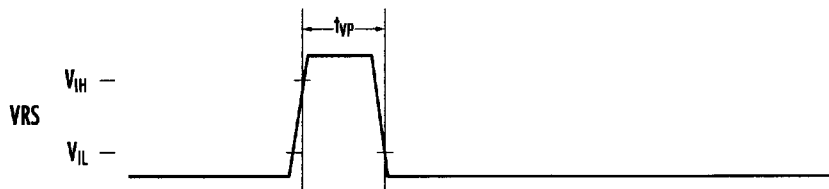
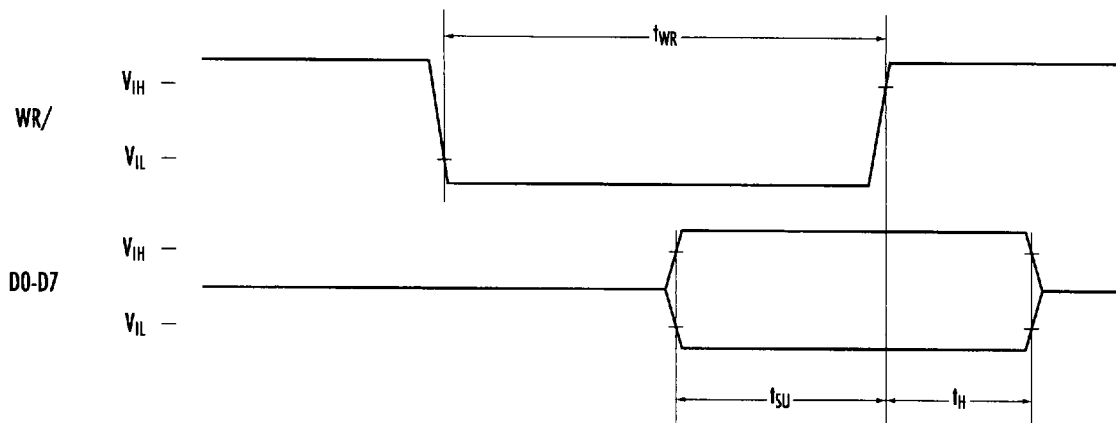

**Table 31. Vocoder Reference Strobe Timing Parameters**

PARAMETER	SYMBOL	MIN	MAX	UNITS
Pulse Period (Low to High)	$t_{YP}$	$2T^*$	—	ns

\* $T = t_{IH}$

**Figure 22. Write Timing Diagram**

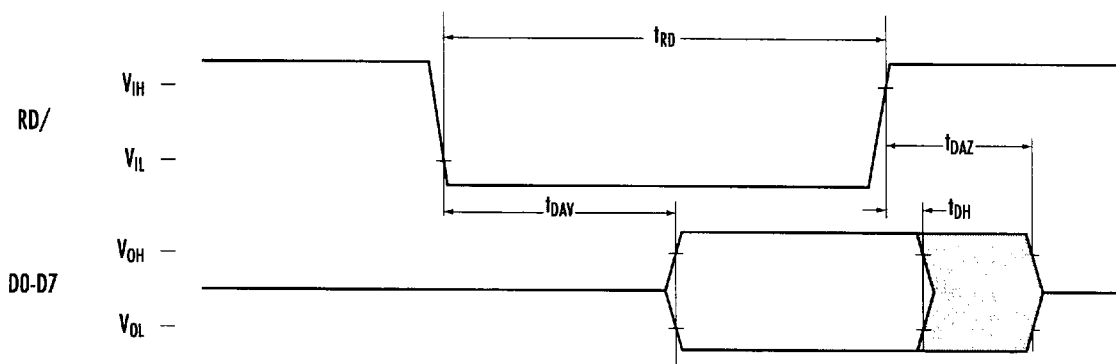

**Table 32. Write Timing Parameters**

PARAMETER	SYMBOL	MIN	MAX	UNITS
WR/ Pulse Width (Low to High)	t <sub>WR</sub>	T*	—	ns
D0-D7 Setup Time (Valid to High)	t <sub>SU</sub>	8	—	ns
D0-D7 Hold Time (High to Valid)	t <sub>H</sub>	0	—	ns

\*T = t<sub>IN</sub>

**Figure 23. Read Timing Diagram**

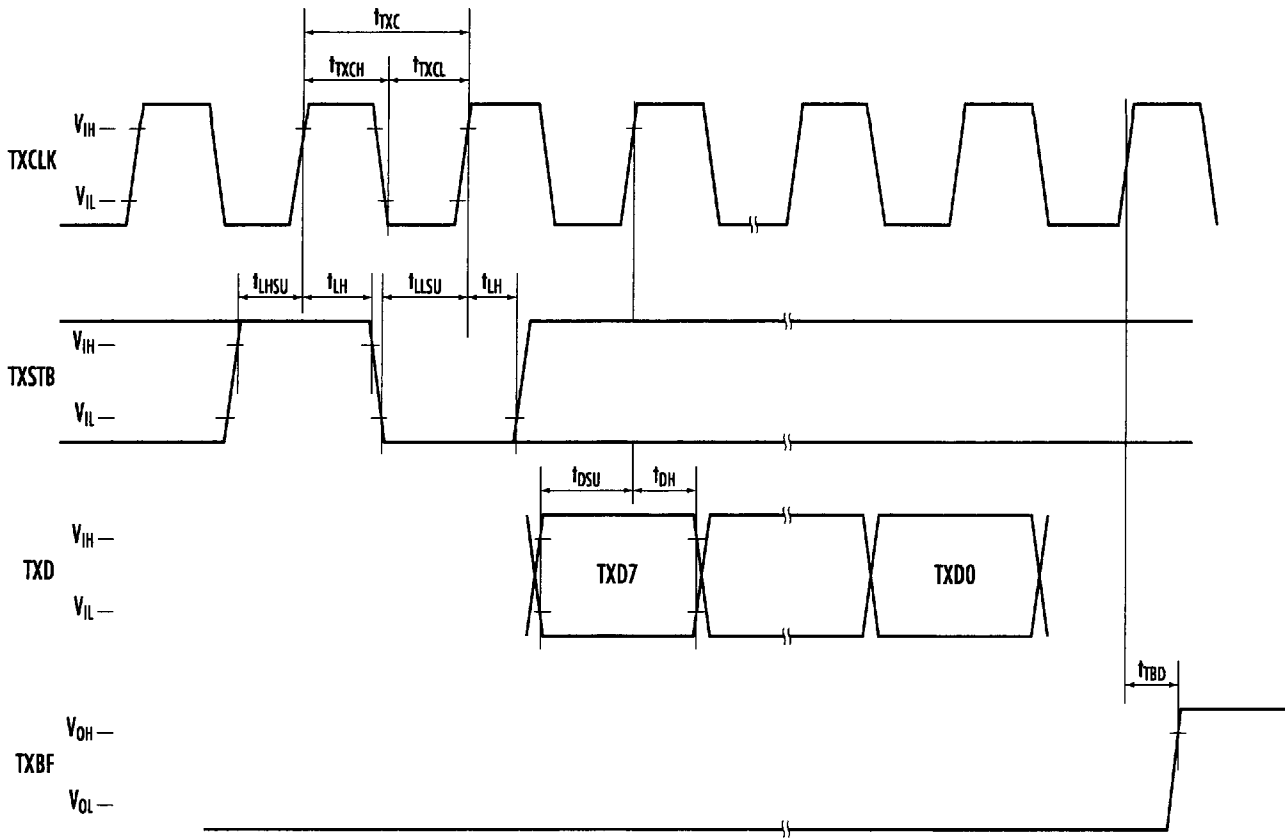

**Table 33. Read Timing Parameters**

PARAMETER	SYMBOL	MIN	MAX	UNITS
RD/ Pulse Width (Low to High)	t <sub>RD</sub>	T*	—	ns
RD/ Low to D0 to D7 Valid	t <sub>DAV</sub>	—	28	ns
RD/ High to D0 to D7 Tri-state	t <sub>DAZ</sub>	—	20	ns
Data Hold After RD/ Rising	t <sub>DH</sub>	6	—	ns

\*T = t<sub>IN</sub>

**Figure 24. PCM Tx Timing Diagram**



**Table 34. PCM Tx Timing Parameters**

PARAMETER	SYMBOL	MIN	MAX	UNITS
TXCLK Period (High to High)	$t_{TXC}$	66	—	ns
TXCLK Low Time (Low to High)	$t_{TXCL}$	30	—	ns
TXCLK High Time (High to Low)	$t_{TXCH}$	30	—	ns
TXSTB High Setup (High to High)	$t_{LHSU}$	5	—	ns
TXSTB Low Setup (Low to High)	$t_{LLSU}$	5	—	ns
TXSTB Hold (High to Invalid)	$t_{LH}$	4	—	ns
TXD Setup (Valid to High)	$t_{DSU}$	5	—	ns
TXD Hold (High to Invalid)	$t_{DH}$	4	—	ns
TXBF Delay (High to Invalid)	$t_{TBD}$	—	35	ns

Figure 25. PCM Rx Timing Diagram

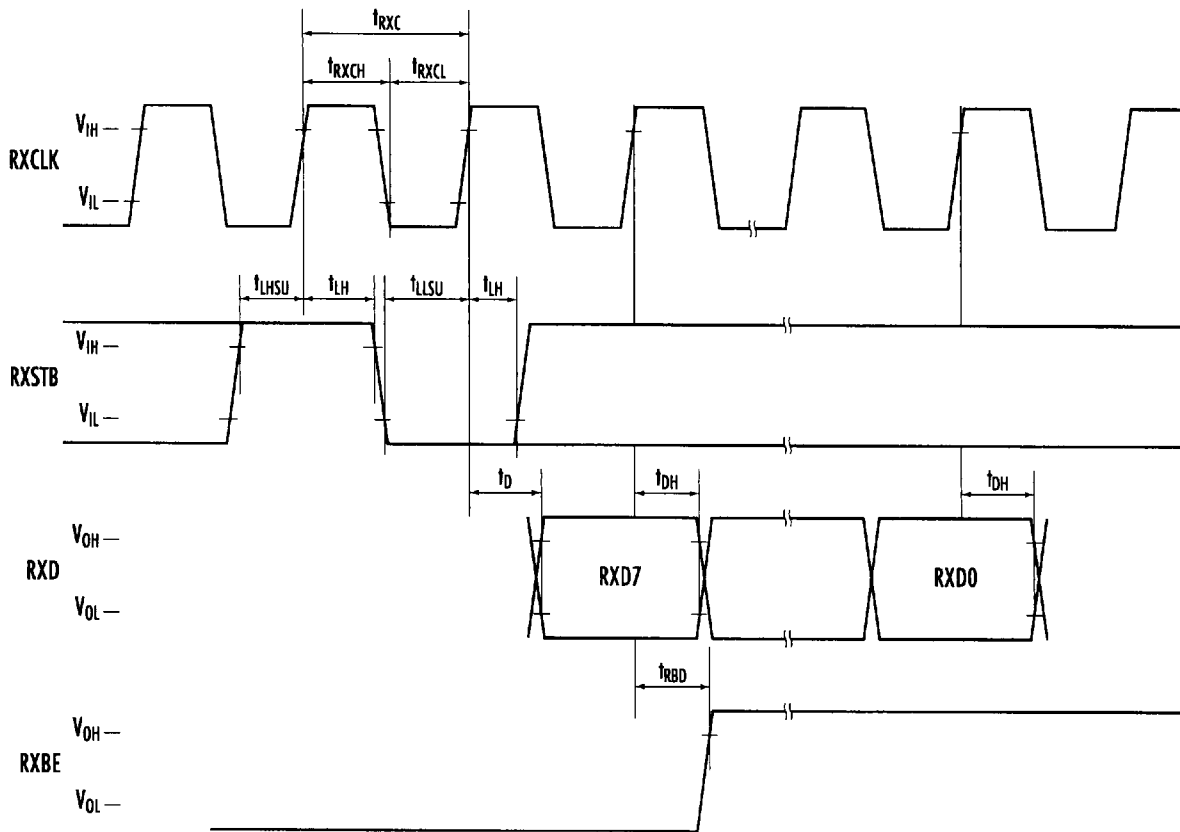

Table 35. PCM Rx Timing Parameters

PARAMETER	SYMBOL	MIN	MAX	UNITS
RXCLK Period (High to High)	$t_{RXC}$	66	—	ns
RXCLK Low Time (Low to High)	$t_{RXCL}$	30	—	ns
RXCLK High Time (High to Low)	$t_{RXCH}$	30	—	ns
RXSTB High Setup (High to High)	$t_{LHSU}$	5	—	ns
RXSTB Low Setup (Low to High)	$t_{LLSU}$	5	—	ns
RXSTB Hold (High to Invalid)	$t_{LH}$	4	—	ns
RXD Delay (High to Valid)	$t_D$	—	35	ns
RXD Hold (High to Invalid)	$t_{DH}$	5	—	ns
RXBE Delay (High to High)	$t_{RBD}$	—	35	ns

## Q4401 VARIABLE RATE VOCODER PACKAGING

The Q4401 can be packaged in either a 100-pin plastic quad flat pack (PQFP) or a 100-pin thin quad flat pack (TQFP). Figures 26 and 27 show the package outlines

and dimensions. A recommended socket for the PQFP package is: 3M P/N 2-0100-07243-000-018-007.

**Figure 26. Q4401 Variable Rate Vocoder 100-pin PQFP Packaging**

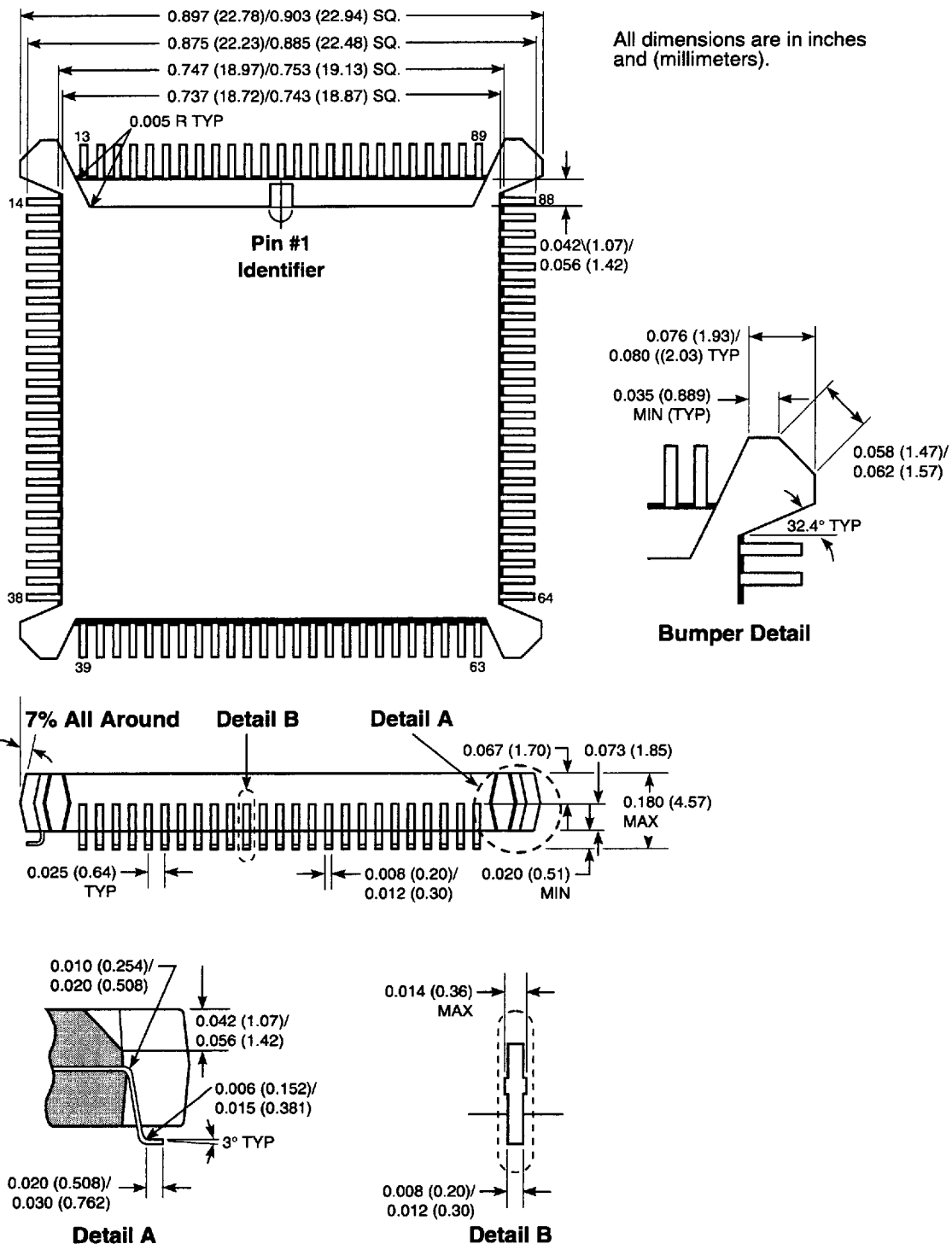

**Figure 27. Q4401 Variable Rate Vocoder 100-pin TQFP Packaging**

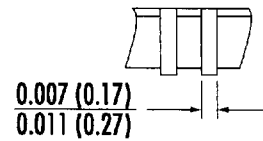
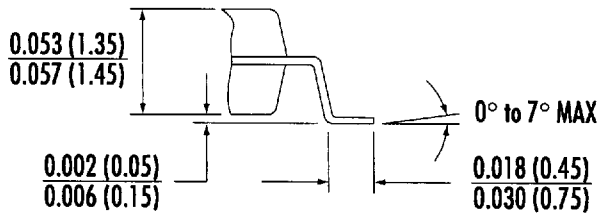
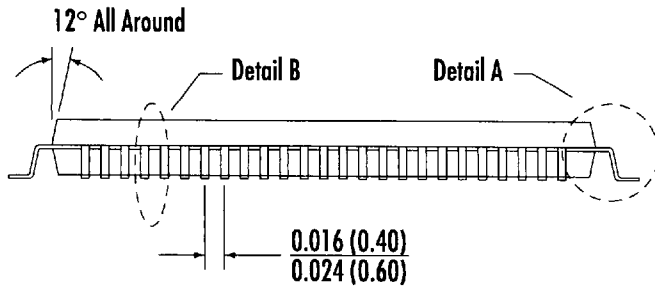
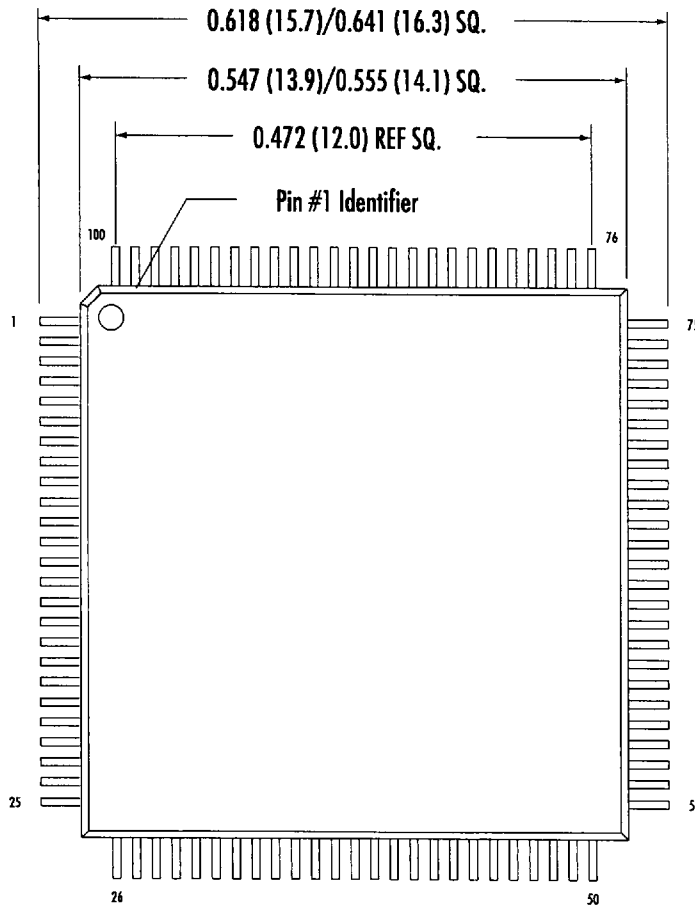

**Detail A**

**Detail B**

All dimensions are in inches and (millimeters).

## APPLICATIONS INFORMATION

Figure 28 illustrates how the Q4401 Variable Rate Vocoder can be used in a voice compression system.

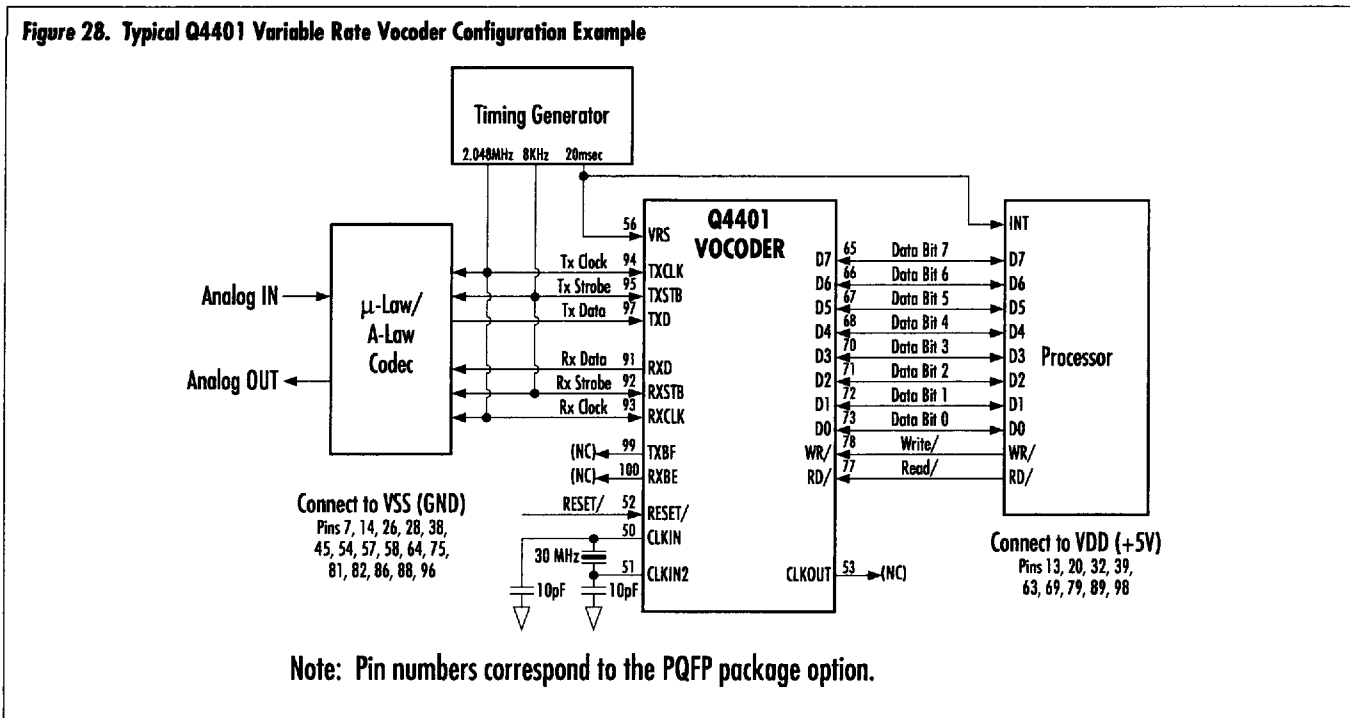

## REFERENCES

AT&T WE® DSP1616X11 Digital Signal Processor  
Preliminary Data Sheet, October 1993.